



# ZFORCE Z10 ZFORCE Z10-4

## *Owner's Manual*

Read this operator's guide thoroughly. It contains important safety information.

Minimum recommended operator age: 16 or older. Keep this operator's guide with the vehicle at all times.

The removal or modification of evaporative emission-related parts on this OHRV is illegal. Violators may be subject to civil and/or criminal penalties under California and federal law.



# TABLE OF CONTENTS

<b>Foreword</b> .....	<b>1</b>
Welcome .....	1
EVAP System (Evaporative Emission Control System) .....	2
Catalytic Converter .....	2
Signal Words .....	3
Introduction .....	6
Vehicle Identification Numbers / Keys .....	7
Specifications .....	8
<b>Operator Safety</b> .....	<b>14</b>
General Safety Precautions .....	14
Owner Responsibilities .....	18
Safe Riding Gear .....	22
Safety Labels, Locations and Warnings .....	25
Potential Hazard Warnings .....	34
Vehicle Feature Locations and Descriptions .....	50
Controls and Features .....	54
Primary Controls .....	61
Secondary Controls .....	65
Other Features .....	76

CVT System .....	79
Dashboard Indicators and Warnings .....	83
Dashboard Indicators and Warnings .....	86
Ridesync MMI .....	91
<b>Operating Your Vehicle .....</b>	<b>124</b>
Break-In Period .....	124
Pre-Ride Inspection .....	126
Throttle .....	126
Brakes .....	127
Starting the Engine .....	127
Starting a Cold Engine .....	127
Shifting the Transmission .....	128
<b>Safe Operation - Driving Safely .....</b>	<b>132</b>
Responsibilities of the Operator .....	132
Practice Exercises .....	135
Operating Your Vehicle .....	138
Hauling and Towing Loads .....	143
Winch Operation .....	148
<b>Maintenance .....</b>	<b>157</b>
Severe Use Definition .....	157

Key Points Of Lubrication Schedule.....	158
Pre-Ride Maintenance Checklist.....	159
Break-In Maintenance Checklist .....	161
Periodic Maintenance Schedule.....	163
<b>Maintenance Procedures .....</b>	<b>170</b>
Engine .....	173
Front Gear Case .....	179
Front and Rear CV Drive Shaft .....	181
Cooling System .....	182
Spark Plug.....	187
Battery .....	191
Brakes .....	195
Suspension .....	198
Shock Absorbers .....	199
Wheels .....	200
Electrical.....	202
Safety Belts .....	204
<b>Cleaning and Storage.....</b>	<b>205</b>
Washing the Vehicle.....	205
Waxing the Vehicle.....	206

<b>Transporting or Towing the Vehicle .....</b>	<b>209</b>
Transporting .....	209
Towing .....	209
<b>Vehicle Issue Diagnosis.....</b>	<b>210</b>
EFI Malfunction Indicator Light.....	216
EPS Malfunction Indicator Light.....	217
Electronic Power Steering (EPS) Fault Diagnosis and Solution.....	218
<b>CFMOTO Limited Warranty.....</b>	<b>219</b>
Warranty Terms & Conditions .....	219
U.S.A. EPA and CARB Emissions Control Limited Warranty .....	227
Noise Control System and Tampering .....	230
Change of Ownership .....	231
<b>CFMOTO RIDE App / Telematics Box .....</b>	<b>232</b>
<b>CFMOTO RIDESYNC APP / TELEMATICS MODULE (Select Markets)</b>	<b>233</b>
<b>FOX ELECTRONIC SUSPENSION APP (Select Markets) .....</b>	<b>234</b>

## FOREWORD

### Foreword

#### Welcome

Thank you for purchasing a CFMOTO vehicle, and welcome to our world-wide family of CFMOTO enthusiasts. Be sure to visit us online at [www.cfmoto.com](http://www.cfmoto.com) for the latest news, new product introductions, upcoming events, and more.

CFMOTO is an international company that specializes in the development, manufacture, and marketing of all-terrain vehicles, utility vehicles, large displacement motorcycles, and their core components. Founded in 1989, CFMOTO is devoted to the development of independent brand cultivation and R&D innovation. CFMOTO products are currently distributed through more than 2000 companions worldwide in more than 100 countries and regions. CFMOTO is edging into the advanced ranks in the world of powersports, and aims to supply superior products to dealers and fans globally.

For safe and enjoyable operation of your vehicle, be sure to follow the instructions and recommendations in this owner's manual. Your manual contains instructions for minor maintenance. Information about major repairs is outlined in the CFMOTO Service Manual.

Your CFMOTO dealer knows your vehicle best and is interested in your total satisfaction. Be sure to return to your dealership for all of your service needs during, and after, the warranty period.

The information in this manual includes the most current product information available at the time of publishing and may contain product information that does not apply to your particular market. The instructions contained in this publication are not legally binding. CFMOTO reserves the right to modify or completely delete technical instructions, service instructions, maintenance instructions, prices, colors, shapes, materials, designs, configurations and similar content without prior notice and without reason. Due to continuous improvements in the design and quality of production components, minor discrepancies may result between the actual vehicle and the information provided within. No liability can be accepted for omissions, deviations, inaccuracies, printing defects or errors in the delivery method, drawings and instructions. Any reproduction or reuse of the images, descriptions and/or procedures within, whether whole or in part, is expressly prohibited without written permission from the copyright holder.

This manual applies to the following models: CF1000SU, CF1000SU-L, CF1000SZ, CF1000SZ-L, CM1000SU, CM1000SU-L, CM1000SZ, CM1000SZ-L

## FOREWORD

### **EVAP System (Evaporative Emission Control System)**

**(If equipped)**

When required by environmental emissions regulations, this vehicle is manufactured with a fuel evaporation system (EVAP) to prevent fuel vapors entering the atmosphere from the fuel tank and fuel system. During routine maintenance, visually inspect all hose connections for leaks or blockage. Ensure the hoses are not clogged or kinked, which could damage the fuel pump or distort the fuel tank. No other maintenance is necessary.

Contact your dealer if repair is required. Do not modify the EVAP system. Modifying any part of this system will violate environmental emissions regulations.

### **Catalytic Converter**

**CAUTION: Please pay attention to the following to protect your catalytic converter:**

- Use only unleaded gasoline. Even gasoline that contains a little lead could damage the reactive metals contained in the catalytic converter and disable it.
- Never add rust preventive oil or engine oil into the muffler. Doing so could damage the catalytic converter.

NOTE
<p><b>Some features described within this manual may not apply to models sold in North America.</b></p> <p><b>All descriptions and directions given are from the operator's perspective when properly seated.</b></p> <p><b>The owner's manual contains most of the configurations. Some of it may not suit your purchased one, selectively read the content in the manual according to the real vehicle configuration.</b></p>

## FOREWORD

### Signal Words

A signal word calls attention to a safety message or messages, a property damage message or messages, and designates a degree or level of hazard seriousness. The standard signal words in this manual are DANGER, WARNING, CAUTION and NOTE or NOTICE.

The following signal words and symbols appear throughout this manual and on your vehicle. Your safety is involved when these words and symbols are used. Become familiar with their meanings before reading the manual:

#### **DANGER**

This safety alert and icon indicates a potential hazard that may result in serious injury or death.

#### **WARNING**

This safety alert and icon indicates a potential hazard that may result in minor or moderate personal injury and/or damage to the vehicle.

#### **CAUTION**

This safety alert without an icon indicates a situation that may result in damage to the vehicle.

#### **NOTE or NOTICE**

A note or notice will alert you to important information or instructions.

## FOREWORD



### NEVER:

- Operate without proper training or instruction.
- Operate on public roads. A collision can occur with another vehicle.
- Operate on paved roads. Pavement may seriously affect handling and control.
- Operate at speeds too fast for your skill, conditions, or the terrain.
- Use ALCOHOL or DRUGS before or while driving this vehicle.

### ALWAYS:

- Avoid paved surfaces, which may adversely affect the handling and control.
- Use proper driving techniques to avoid vehicle overturn on hills, rough terrain, and when turning.
- Wear eye protection, helmet and protective clothing.

**FOREWORD**  
**READ THE OWNER'S MANUAL**  
**FOLLOW ALL INSTRUCTIONS AND WARNINGS**

** WARNING**

**Read, understand, and follow all of the instructions and safety precautions in this manual and on all product labels. Failure to follow the safety precautions could result in serious injury or death.**

** WARNING**

**Operating, servicing and maintaining the vehicle can expose you to chemicals including engine exhaust, carbon monoxide, phthalates, and lead, which are known to cause cancer and birth defects or other reproductive harm. To minimize exposure, avoid breathing exhaust, do not idle the engine except as necessary, service your vehicle in a well-ventilated area and wear gloves or wash your hands frequently when servicing your vehicle.**

## INTRODUCTION

### Introduction

Thank you for purchasing a CFMOTO vehicle, and welcome to our world-wide family of CFMOTO enthusiasts.

For safe and enjoyable operation of your vehicle, be sure to follow the instructions and recommendations in this owner's manual. Information about major repairs are outlined in the CFMOTO Service Manual, and should only be performed by a CFMOTO service dealer and technician. Be sure to return to your dealership for all of your service needs during, and after, the warranty period.

If you have questions or concerns about your vehicle

All questions or concerns related to your vehicle should be directed to your local CFMOTO dealer first. Your dealer knows your vehicle best and is interested in your total satisfaction. In the event your local dealer is unable to resolve a product issue or concern, you can reach a CFMOTO customer service representative depending on the market you reside in:

For USA: Please contact CFMOTO POWERSPORTS, INC. TEL: 763-398-2690, by e-mail: [info@cfmotousa.com](mailto:info@cfmotousa.com), or online: <https://cfmotousa.com/customer-care/customer-care-contact>. Please note that customer service does not have authority to approve or deny warranty, and cannot provide technical repair data, diagnosis, or instructions.

For CANADA: Please contact CANADA MOTOR IMPORT INC. TEL: 1-418-227-2077, or online: <https://www.cfmoto.ca/en/customer-care/>.

For a safety concern related to your Canadian vehicle, you may report your concern to Transport Canada Defect Investigation and Recalls Division by mail, telephone, or online using the contact information below:

Mailing address: Transport Canada - ASFAD, 330 Sparks Street, Ottawa, ON, K1A 0N5

TEL: 819-994-3328 (Ottawa-Gatineau area or international) or toll-free: 1-800-333-0510 (In Canada)

Online: <http://www.tc.gc.ca/recalls>

## INTRODUCTION

### Vehicle Identification Numbers / Keys

Record your vehicle's identification numbers in the spaces provided. Remove the spare NFC key and store in a safe place. If both NFC keys are lost, contact your dealer to rematch.

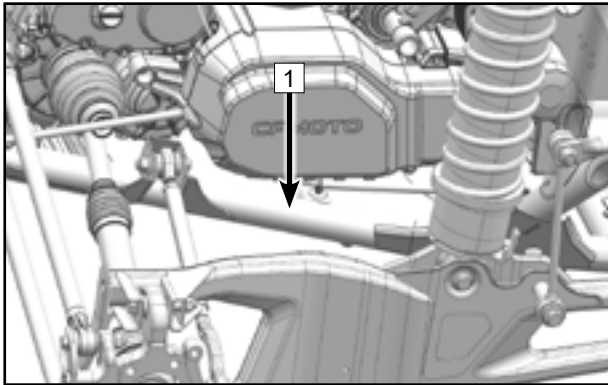

1. Vehicle Identification Number: \_\_\_\_\_

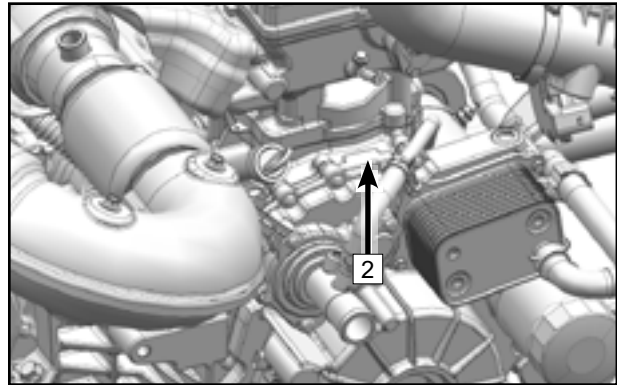

2. Engine Serial Number: \_\_\_\_\_

## SPECIFICATIONS

### Specifications

Item	Z10	Z10-4
	CF1000SU/CM1000SU CF1000SZ/CM1000SZ	CF1000SU-L/CM1000SU-L CF1000SZ-L/CM1000SZ-L
Overall Length	129 in. (3277 mm)	159 in. (4039 mm)
Overall Width	65 in. (1651 mm - outermost edge of tire) 64 in. (1625 mm - outermost edge of rim)	
Overall Height	68.5 in. (1740 mm)	
Wheel Base	99 in. (2515 mm)	129 in. (3277 mm)
Ground Clearance	14 in. (356 mm)	
Minimum Turning Radius	216.5 in. (5500 mm)	288.3 in. (7325 mm)
Curb Weight	1962 lb. (890 kg)	2204 lb. (1000 kg)
Rear Cargo Box Weight Capacity	198 lb. (90 kg)	
Maximum Vehicle Load Allowed	650 lb. (295 kg)	881 lb. (400 kg)
Recommended Towing Capacities:		
Towing Hitch Weight	88.2 lb. (40 kg)	
Trailer and Cargo Weight	882 lb. (400 kg)	
Engine Model And Type	380Y-2A	
Type	In-line three-cylinder, 4-stroke, liquid-cooled, 4-valve, DOHC	

## SPECIFICATIONS

Item	Z10	Z10-4
	CF1000SU/CM1000SU CF1000SZ/CM1000SZ	CF1000SU-L/CM1000SU-L CF1000SZ-L/CM1000SZ-L
Bore × Stroke	3.1 in. x 2.6 in. (80 mm×66.2 mm)	
Displacement	998 cc	
Compression Ratio	9:1	
Starting Type	Electric start	
Lubrication Type	Pressure/Splash lubrication	
Engine Coolant: Type	CFMOTO uses Organic Acid Technology (OAT) coolant in all liquid-cooled engines. Do not mix with inorganic (IAT) coolant.	
Capacity	4.22 qt. (4.0 L)	
Mix Ratio	50% coolant / 50% distilled water	
Engine Oil: Type	SAE 5W-40, SP or higher API, full-synthetic oil	
Oil Volume:	4.43 qt. (4.2 L)	
Capacity Change / Oil Filter	4.01 qt. (3.8 L)	
Oil Change Only	3.69 qt. (3.5 L)	
Transmission Type	SAE 75W-90 GL-5	
Oil Volume	3.17 qt. (3 L)	

## SPECIFICATIONS

Item	Z10	Z10-4
	CF1000SU/CM1000SU CF1000SZ/CM1000SZ	CF1000SU-L/CM1000SU-L CF1000SZ-L/CM1000SZ-L
Front gear case Type:	SAE 80W-90 GL-5	
Volume:	9.5 oz. (280 ml)	
Air Filter	Paper media	
Fuel Type	89 octane or higher unleaded gasoline	
Fuel Tank Capacity	11.89 gal. (45 L)	
Fuel Reserve Amount At Fuel Gauge 'Flash' (Approximate)	1.16 gal. (4.4 L)	

## SPECIFICATIONS

Item		Z10	Z10-4
		CF1000SU/CM1000SU CF1000SZ/CM1000SZ	CF1000SU-L/CM1000SU-L CF1000SZ-L/CM1000SZ-L
Spark Plug Type		BN8RTI	
Spark Plug Gap		0.8 ±0.1mm	
Transmission	Transmission		CVT + Gearbox
	Gear Shift/Order		Manual / P-R-N-H-L
	CVT Ratio		Z10 / Z10-4: 0.733-3.225
	Gear Ratio	Low Gear	22.152
		High Gear	10.02 (CF1000SU-4 / CF1000SZ-4 / CF1000SZ-6L / CF1000SU-6L) 10.8 (CF1000SU / CF1000SZ / CF1000SU-L / CF1000SZ-L)
Reverse		19.545	
Chassis Frame		Steel tube	
Tires:			
Type	Tubeless		
Front	30×10.00R14		
Rear	30×10.00R14		
Wheel Bolt Pattern		5×114.3 mm	

## SPECIFICATIONS

Item	Z10	Z10-4
	CF1000SU/CM1000SU CF1000SZ/CM1000SZ	CF1000SU-L/CM1000SU-L CF1000SZ-L/CM1000SZ-L
Tire Pressure Front:  Rear:	Recommended: 21.7 Psi (150 kPa) Full-load: 21.7 Psi (150 kPa)  Recommended: 21.7 Psi (150 kPa) Full-load: 24.6 Psi (170 kPa)	Recommended: 21.7 Psi (150 kPa) Full-load: 21.7 Psi (150 kPa)  Recommended: 21.7 Psi (150 kPa) Full-load: 27.5 Psi (190kPa)
Brake System	Front: Disc / Rear: Disc	
Foot Brake Type/ Operation:	Foot operated Four wheel disc	
Parking Brake Type/ Operation:	P gear / Mechanical parking (If equipped) Gearshift lever / Parking lever (If equipped)	
Brake Fluid Type	DOT 4	
Suspension Front: Rear:	Double A-arm independent Multi-link independent suspension	

## SPECIFICATIONS

Item	Z10	Z10-4
	CF1000SU/CM1000SU CF1000SZ/CM1000SZ	CF1000SU-L/CM1000SU-L CF1000SZ-L/CM1000SZ-L
Shock Absorbers		
Front:	Air spring / Electronically adjustable damper	
Rear:	Air spring / Electronically adjustable damper	
Wheel Travel		
Front:	16.9 in. (430 mm)	
Rear:	20 in. (508 mm)	
Electrical System		
Ignition:	Electronic	
Charging:	Rectified A/C 900 Watt @ 6000 rpm	
Battery:	12 Vdc / 32 Amp Hr	

## OPERATOR SAFETY

### Operator Safety

#### General Safety Precautions

 **DANGER**

**Failure to heed the warnings contained in this manual can result in serious injury or death. This vehicle is not a toy and can be hazardous to operate. This vehicle handles differently from other vehicles, such as motorcycles and cars. A collision or rollover can occur quickly, even during routine maneuvers like turning or driving over obstacles, if you fail to take proper precautions.**

**Read this owner's manual. Understand all safety warnings, precautions and operating procedures before operating this vehicle.**

#### Age Restrictions

This vehicle is an **ADULT VEHICLE ONLY**. Operation is prohibited for anyone under the age of 16. No passengers under age 12 are allowed on CFMOTO vehicles designed to carry passengers.

#### Know Your Vehicle

As the operator of the vehicle, you are responsible for your personal safety, the safety of others, and the protection of the environment. Read and understand your owner's manual, which includes valuable information about all aspects of your vehicle, including safe operating procedures.

# OPERATOR SAFETY

## Equipment Modifications

CFMOTO is concerned with the safety of our customers and for the general public. Therefore, we strongly recommend that consumers do not install on a vehicle, any equipment that may increase the speed or power of the vehicle, or make any other modifications to the vehicle for these purposes. Any modifications to the original equipment of the vehicle create a substantial safety hazard and increase the risk of body injury. The warranty on your vehicle is terminated if any unapproved accessory equipment has been added to the vehicle, or if any modifications have been made to the vehicle that increase its speed or power.

### CAUTION

**The addition of certain accessory equipment which may change the handling and performance characteristics of the vehicle include, but are not limited to; mowers, plow blades, oversize tires, sprayers, large racks, lift kits and trailers. Use only approved accessories, and familiarize yourself with their function and effect on the vehicle.**

## Avoid Carbon Monoxide Poisoning

All engine exhaust contains carbon monoxide, a deadly gas. Breathing carbon monoxide can cause headaches, dizziness, drowsiness, nausea, confusion and eventually death.

Carbon monoxide is a colorless, odorless, tasteless gas that may be present even if you do not see or smell any engine exhaust. Deadly levels of carbon monoxide can collect rapidly, and you can quickly be overcome and unable to save yourself. Also, deadly levels of carbon monoxide can linger for hours or days in enclosed or poorly ventilated areas.

To prevent serious injury or death from carbon monoxide:

- Never run the vehicle in poorly ventilated or partially enclosed areas.
- Never run the vehicle outdoor where engine exhaust can be drawn into a building through openings such as windows and doors.

## OPERATOR SAFETY

### Avoid Gasoline Fires and Other Hazards

Gasoline is extremely flammable and highly explosive. Fuel vapors can spread and be ignited by a spark or flame many feet away from the engine.

To reduce the risk of fire or explosion, follow these instructions:

- Use only an approved gasoline container to store fuel.
- Never fill the gasoline container in the vehicle cargo box or on the vehicle. An electrical static discharge may ignite the fuel.
- Strictly adhere to proper fueling procedures.
- Never start or operate the engine if the fuel cap is not properly installed. Gasoline is poisonous and can cause injury or death.
- Never siphon gasoline by mouth.
- If you swallow gasoline, get any in your eye(s), or inhale gasoline vapor, see a doctor immediately.
- If gasoline spills on you, wash with soap and water and change your clothes.

### WARNING

**Gasoline is highly flammable and explosive under certain conditions. Allow the engine and exhaust system to cool before filling the tank. Always be highly cautious whenever handling gasoline. Always refuel the vehicle when the engine is stopped outdoors or in a well-ventilated area. Do not smoke or allow open flames or sparks in or near the area where refueling is performed, or where gasoline is stored.**

**Do not overfill the tank. Do not fill fuel to the tank neck.**

**If gasoline spills on your skin or clothing, immediately wash it off with soap and water and change clothing. Never start the engine or let it run in an enclosed area. Engine exhaust fumes are poisonous and can cause loss of consciousness or death in a short time. The engine exhaust from this product contains chemicals known to cause cancer, birth defects or other reproductive harm. Operate this vehicle only outdoors or in well-ventilated areas.**

## **OPERATOR SAFETY**

### **Fuel Minimum Octane Rating and Safety Warnings**

The recommended fuel for your vehicle is 89 Octane minimum, premium or mid-grade fuel (a maximum blend of 10% ethanol is allowed). Non-oxygenated (ethanol-free) fuel is recommended for best performance in all conditions.

### **Avoid Burns from Hot Parts**

The exhaust system and engine become hot during operation. Avoid contact during and shortly after operation to avoid burns.

### **Inspection after an Accident**

After any overturn or accident, have an authorized dealer inspect the entire vehicle for possible damage. The damage to the vehicle during an accident may be more serious than you think.

# OPERATOR SAFETY

## Owner Responsibilities

### Be Qualified and Responsible

Read this Owner's Manual and the warning decals on this vehicle carefully. Take a safety training course on open areas if available. Practice at low speeds. Higher speeds require greater experience, knowledge and suitable riding conditions. Become completely familiar with the operational controls and the general operation of the vehicle.

This vehicle is an ADULT VEHICLE ONLY. Operation is prohibited for anyone under 16 years of age. Operators must be tall enough with physical capacity to: be properly seated, hold the steering wheel with both hands, and firmly plant their feet on the footrest.

Safe operation of this vehicle requires good judgment and physical skills. Persons with cognitive or physical disabilities who operate this vehicle have an increased risk of overturn and loss of control, which could result in severe injury or death.

Operators may be required to have a proper driver's license in accordance with local laws.

### Carrying a Passenger

- Only carry one passenger (Z10-4 , only 3 passengers are allowed), The passenger must be properly seated in the passenger seat.
- The passenger must be at least 12 years old and tall enough to always be properly seated against the backrest with the seat belt fastened, holding handhold, with both feet firmly planted on the vehicle floor.
- Never carry a passenger who has used drugs or alcohol, or is tired or ill. These slow reaction time and impair judgment.
- Instruct the passenger to read the vehicle's safety labels.
- Never carry a passenger if you judge their ability or judgment is insufficient to concentrate on the terrain conditions and adapt accordingly. More specifically for side-by-side vehicles, the passenger must also pay constant attention to the terrain ahead and be able to brace for bumps.

## OPERATOR SAFETY

### Riding Carefully

- This vehicle is not a toy and can be hazardous to operate. This vehicle handles differently from other vehicles such as motorcycles or cars. A collision or rollover can occur quickly, during abrupt maneuvers such as sharp turns, acceleration or deceleration, and driving on hills or over obstacles if you fail to take proper precautions.
- Never operate at excessive speeds. Always operate at a speed that is proper for the terrain, visibility, operating conditions, load and your experience.
- Never attempt jumps, side slides, donuts, or any other stunts.
- Never attempt rapid acceleration or deceleration when performing a sharp turn. This may result in a rollover.
- Never attempt skidding or sliding. If vehicle starts to skid or slide, counter steer in the direction of skidding or sliding. On extremely slippery surfaces, such as ice, go slowly and be very cautious in order to reduce the chance of skidding out of control.
- Always be sure there are no obstacles or people behind the vehicle when reversing. Pay attention to blind spots. When it is safe to proceed in reverse, go slowly.
- Never exceed the stated load limits for this vehicle. Cargo must be properly secured. Reduce speed, allow for greater braking distance and follow other instructions in this manual.
- Ensure that cargo is well distributed in the cargo box. Otherwise, it could change the center of gravity and may result in rollover.

## **OPERATOR SAFETY**

### **Roll Over Protection System (ROPS)**

- The ROPS on this vehicle meets the performance requirements of ISO 3471:2008. The ROPS can limit intrusions of outside objects and reduce your risk of injury in rollovers.
- Always follow all safe operating practices outlined in this manual to avoid vehicle rollover.
- Do not put your hands and/or feet outside of the vehicle when driving. The ROPS will not protect you from injury in all rollovers.
- Always have your authorized CFMOTO dealer thoroughly inspect the ROPS if it ever becomes damaged in any way.

### **Occupant Restraint System**

- This vehicle requires all occupants to wear proper protective gear.
- The driver and passenger must latch the side doors and wear the seat belts at all times when riding.

### **Terrain Conditions**

- Avoid sharp turns, abrupt acceleration and sudden braking when passing public roads.
- Always go slowly and be extra careful when operating on unfamiliar terrain. Always be alert to changing terrain conditions when operating this vehicle. Take the time to learn how the vehicle performs in different environments.
- Never operate on excessively rough, slippery or loose terrain until you have learned and practiced the skills necessary to control this vehicle on such terrain. Always be especially cautious on these kinds of terrain.
- Never operate this vehicle on hills too steep for the vehicle or your abilities. Practice on small inclines.

## **OPERATOR SAFETY**

- Always follow proper procedures for climbing or going down hills. Never go over the top of any hill at high speed.
- Never attempt steep hills or side hilling when pulling a trailer.
- Always check for obstacles before operating in a new area. Always follow proper procedures when operating over obstacles or fallen trees.
- Never operate this vehicle in deep water or fast flowing water. Remember that wet brakes may have reduced stopping ability. Test your brakes after leaving water. If necessary, apply them several times while driving slowly to let friction dry out the brakes.
- Always ensure to properly park the vehicle on the flattest terrain section available. Put the shift lever in PARK, stop the engine, and remove the key before leaving the vehicle.
- Never assume that the vehicle will go everywhere safely. Sudden changes in terrain caused by holes, depressions, banks, softer or harder ground, or other irregularities may cause the vehicle to topple or become unstable. To avoid this, slow down and always observe the terrain ahead. If the vehicle begins to topple or rollover, hold the steering wheel tightly with both hands and press your body to the seat back. Passengers should be instructed to grasp the handhold tightly with both hands and press the body to the seat back.
- Never attempt to prevent a rollover with your arms or legs. Always keep limbs inside the ROPS cage.

## OPERATOR SAFETY

### Safe Riding Gear

Always wear clothing suited to the type of riding. Offroad riding requires special protective clothing for comfort and to reduce the chance of injury:

- 1 An approved helmet
- 2 Eye protection.
- 3 Gloves
- 4 Long-sleeved shirts or jackets
- 5 Long pants
- 6 Over-the-ankle boots

Depending on weather conditions, extra apparel such as anti-fog eye protection, thermal underwear and a face guard may be required for cold weather. The operator must never wear loose clothing that may get entangled in the vehicle or on tree branches and shrubs.

### Helmet and Eye Protection

An approved helmet can prevent a serious head injury if an accident occurs. Please note that even the best helmet is no guarantee against injury.

The helmet you choose should meet the standard for your country or area. A closed-face helmet with face shield will be better at preventing impacts from insects, flying rocks, dust and scattered debris, etc.

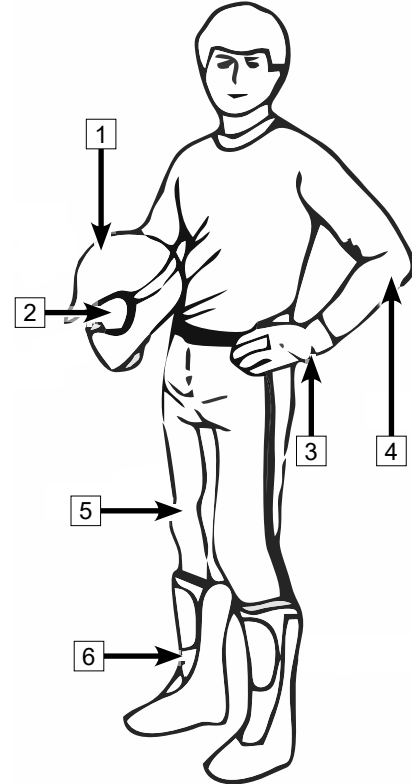

## **OPERATOR SAFETY**

An open-face helmet cannot offer the same protection for your face and jaw. Please wear detachable face masks and goggles when wearing an open-face helmet.

Do not depend on eyeglasses or sunglasses for eye protection. They are not sufficient for impact protection. Debris may fly up and break the lens, causing eye injury.

Use tinted masks or goggles in the daytime only, do not use them at night or in poor lighting. They may impair your ability to distinguish colors. Do not use them if your color discrimination is affected.

### **Gloves**

Full-finger gloves could protect your hands from wind, sun, heat, cold, and splash. Well-fitted gloves are helpful for steering and relieve hand fatigue. If the gloves are too heavy, it will be difficult to operate the vehicle.

A pair of strong offroad riding gloves offer protection for your hands in the event of an accident or turnover. Snowmobile gloves offer better protection when operating in cold areas.

### **Jackets, Pants and Riding Suits**

Wear a jacket or a long sleeved shirt and long pants, or a full riding suit. Quality protective gear will provide comfort, and it can help you avoid being distracted by adverse environmental elements. In case of an accident, good quality protective gear made of sturdy material may prevent or reduce injury.

In cold-weather riding, protect yourself against hypothermia. Hypothermia, a condition of low body temperature, can cause loss of concentration, slowed reactions and loss of smooth, precise muscle movement. In cool conditions, proper protective gear like a windproof jacket and insulated layers of clothing are essential. Even while riding at moderate temperatures, you can feel very cold due to the wind. Protective gear that is appropriate for cold-weather riding may be too hot when stopped. Dress in layers so that clothing can be removed as desired. Topping the protective gear with a windproof outer layer can prevent cold air from reaching the skin.

## **OPERATOR SAFETY**

### **Boots**

Always wear closed-toe, over-the-ankle boots. Sturdy over-the-ankle boots with non-slip soles offer more protection, and allow you to plant your foot properly on the floorboard. Avoid long shoelaces that could get tangled in the vehicle components. For winter riding conditions, rubber-soled boots with either nylon or leather uppers and removable felt liners are best suited. Avoid rubber rain boots. Rubber rain boots may get trapped behind the foot brake pedal, impairing proper operation.

### **Other Riding Gear**

#### **Rain Gear**

When riding in rainy weather, a rain suit or a waterproof riding suit is recommended. On long rides, it is a good idea to carry rain gear. Keeping clothes dry results in being much more comfortable and alert.

#### **Hearing Protection**

Long-term exposure to wind and engine noise when riding can cause permanent hearing loss. Properly worn hearing protective devices such as earplugs can help prevent hearing loss. Check local laws before using any hearing protective devices.

## OPERATOR SAFETY

### Safety Labels, Locations and Warnings

Warning labels have been placed on the vehicle for your protection. Read and follow the instructions on each decal carefully. If a decal becomes illegible or comes off, contact your dealer to purchase a replacement. Read and follow the safety warnings in this manual. Warning labels in the owner's manual are for reference.

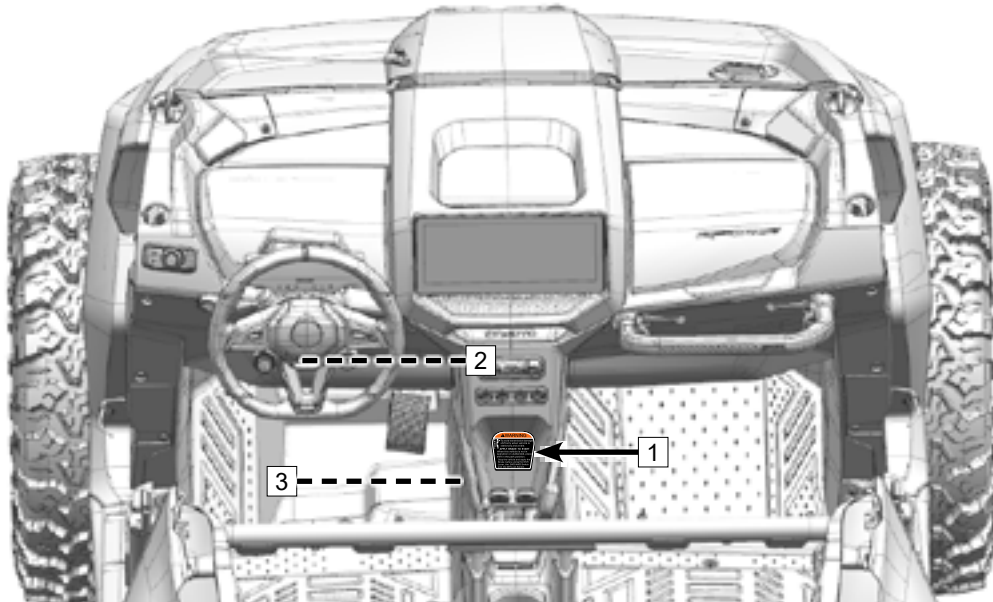

Z10

## OPERATOR SAFETY

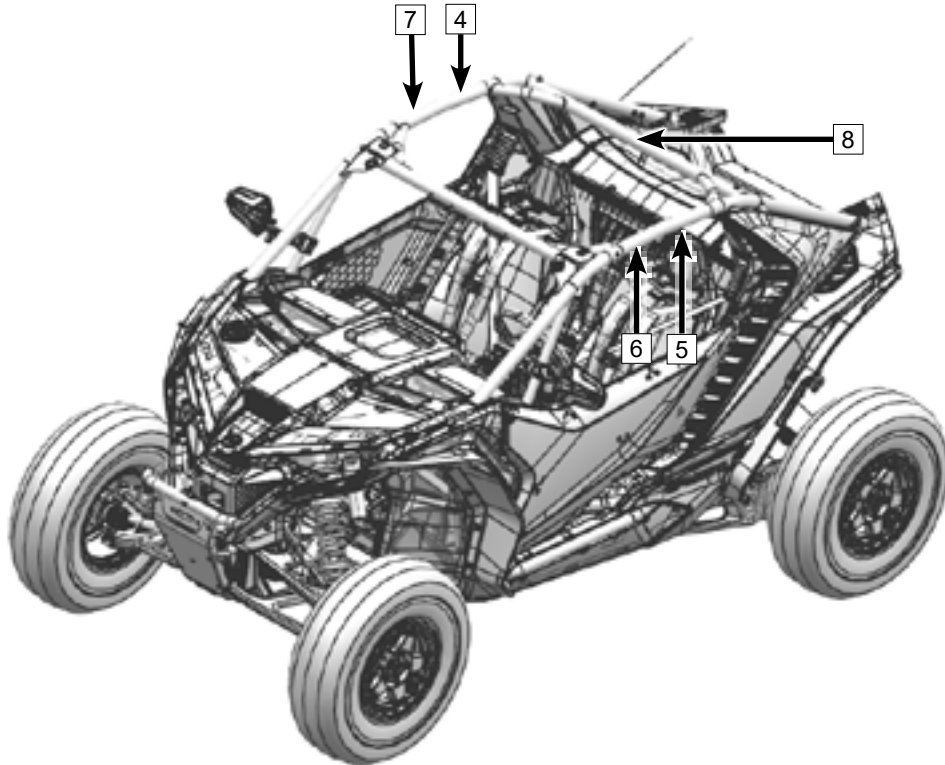

# OPERATOR SAFETY

Z10-4

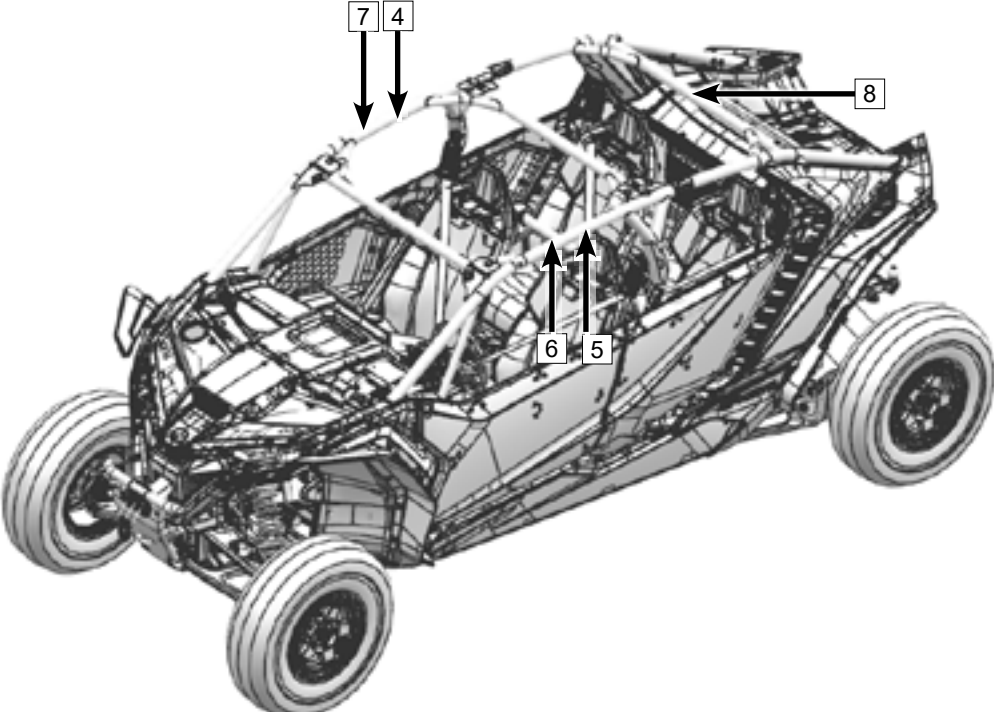

## OPERATOR SAFETY

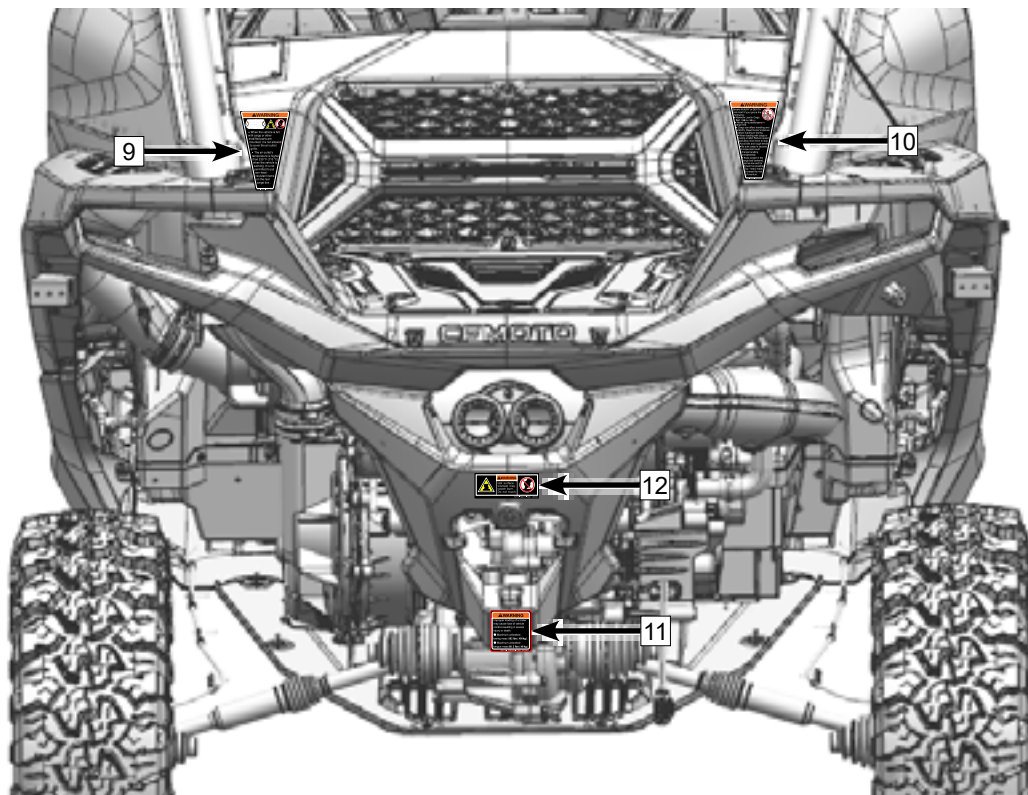

## OPERATOR SAFETY

1



2

CFMOTO Powersports, Inc. certifies that this Recreational Off-Highway Vehicle complies with the current voluntary and applicable American National Standards for ANSI/ROHVA safety standards of the U.S. Consumer Product Safety Commission.

5HY0-190009-1 US189

3



# OPERATOR SAFETY

4

Z10

**⚠ WARNING**

**Require Proper Use of Your Vehicle**  
Do your part to prevent injuries:

- Do not allow careless or reckless driving.
- Make sure operators are 16 or older with a valid driver's license.
- Do not let people drive or ride after using alcohol or drugs.
- Do not allow operation on public roads (unless designated for off-highway vehicle access) - collisions with cars and trucks can occur.
- Do not exceed seating capacity: 2 occupants.



DRIVER  
UNDER  
16



Improper tire pressure or overloading can cause loss of control. Loss of control can result in severe injury or death.

- Cold tire pressure:  
Front: 22 psi (150kPa)  
Rear: 22 psi (150kPa)
- Maximum weight capacity:  
650 lbs. (295kg)

Read the Operator's Guide and Safety Labels and watch the Safety Video. Follow All Instruction and Warnings.

5DYV-190003-1000 US249

Z10-4

**⚠ WARNING**

**Require Proper Use of Your Vehicle**  
Do your part to prevent injuries:

- Do not allow careless or reckless driving.
- Make sure operators are 16 or older with a valid driver's license.
- Do not let people drive or ride after using alcohol or drugs.
- Do not allow operation on public roads (unless designated for off-highway vehicle access) - collisions with cars and trucks can occur.
- Do not exceed seating capacity: 4 occupants.



DRIVER  
UNDER  
16



Improper tire pressure or overloading can cause loss of control. Loss of control can result in severe injury or death.

- Cold tire pressure:  
Front: 22 psi (150kPa)  
Rear: 22 psi (150kPa)
- Maximum weight capacity:  
882 lbs. (400kg)

Read the Operator's Guide and Safety Labels and watch the Safety Video. Follow All Instruction and Warnings.

5CYV-190003-1000 US249

# OPERATOR SAFETY

5

**⚠ WARNING**

**Improper Use of Off-Highway Vehicles Can Cause Severe Injury or Death Be Prepared**

- Fasten seat belts and make sure nets or doors are securely latched in place.
- Wear an approved helmet and protective gear.
- Each rider must be able to sit with back against seat, feet flat on floor or on foot rests, and hands on steering wheel or handholds. Stay completely inside the vehicle.

**Drive Responsibly**

Avoid loss of control and rollovers:



- Avoid abrupt maneuvers, sideways sliding, skidding, or fishtailing, and never do donuts.
- Slow down before entering a turn.
- Avoid hard acceleration when turning, even from a stop.
- Plan for hills, rough terrain, ruts, and other changes in traction and terrain.
- Avoid paved surfaces.
- Avoid side hilling (riding across slopes).

**Read the Operator's Guide and Safety Labels and watch the Safety Video. Follow All Instruction and Warnings.**

**Be Sure Riders Pay Attention and Plan Ahead**

If you think or feel the vehicle may tip or roll, reduce your risk to injury:

- Keep a firm grip on the steering wheel or handholds and brace yourself.
- Do not put any part of your body outside of the vehicle for any reason.

Rollovers have caused severe injuries and death, even on flat, open areas.

5HYV-190009-6000 US234

6

**⚠ WARNING**



Always fasten the seat belts.



Never hold the cage while riding.



Never try to stop a rollover using your arm or leg.

5HYV-190021-7000 EU246

7

**⚠ WARNING**



Always fasten the seat belts.



Never hold the cage while riding.



Never try to stop a rollover using your arm or leg.

5HYV-190022-7000 EU246

# OPERATOR SAFETY

8

Z10



Z10-4



# OPERATOR SAFETY

9

**⚠ WARNING**



- When the vehicle is full with cargo or other modified parts are mounted, it is not allowed to cover the air outlet grille.
- The air outlet's temperature is higher than 230 °F (110 °C) when the vehicle is working. It is not permitted to put non-heat-resistant items on the rear cargo box .

5DYV-19005-1000 US24A

10

**⚠ WARNING**

Severe **INJURY** or **DEATH** can result if you ignore the following:



- Maximum Load in Cargo Bed: 199 lbs. (90 kg).
- Never carry passengers in cargo bed.
- Cargo can affect handling and stability. Read Owner's Manual before loading or towing.
- When loading with cargo or towing a trailer: Reduce speed and allow more room to stop. Avoid hills and rough terrain.
- Be sure cargo is secured. A loose load could change handling unexpectedly.
- Keep weight in the cargo bed centered, and as low and far forward as possible. Top - heavy loads increase the risk of overturn.

5DYV-19005-1000 US24A

11

**⚠ WARNING**

Improper loading of a trailer may cause loss of vehicle control, resulting in severe injury or death.

- Maximum unbraked towing mass **882 lbs. (400 kg)**.
- Maximum unbraked tongue mass **88.2 lbs. (40 kg)**.

5DYV-19005-1000 US249

12

**⚠ WARNING**



Hot surface. Contact may cause burn. Do not touch.

5DYV-190011-1000 US24A

## OPERATOR SAFETY

### Potential Hazard Warnings

#### **WARNING**

##### **POTENTIAL HAZARD:**

Operating this vehicle without proper instruction.

##### **WHAT CAN HAPPEN:**

The risk of an accident is greatly increased if the operator does not know how to operate the vehicle properly in different situations and on different types of terrain.

##### **HOW TO AVOID THE HAZARD:**

Beginning and inexperienced operators should complete a safety training course if offered by dealer. Operators should regularly practice the skills learned in the course and the operating techniques described in the owner's manual.

#### **WARNING**

##### **POTENTIAL HAZARD:**

Failure to follow the age recommendations for this vehicle.

##### **WHAT CAN HAPPEN:**

Severe injury and/or death could occur if a child under the minimum age recommendation operates this vehicle. Even though a child may be within the recommended age group for operating, he/she may not have the skills, abilities, or judgment needed to operate safely and could be susceptible to accident or injury.

##### **HOW TO AVOID THE HAZARD:**

Operation is prohibited for anyone under 16 years of age.

## OPERATOR SAFETY

### **WARNING**

#### **POTENTIAL HAZARD:**

Carrying more passengers than the rated capacity.

#### **WHAT CAN HAPPEN:**

A passenger not seated in the vehicle could be ejected from the vehicle unexpectedly or make contact with moving components, both of which can result in severe injury or death.

#### **HOW TO AVOID THE HAZARD:**

Never allow carrying more passengers than the vehicle allowed.

### **WARNING**

#### **POTENTIAL HAZARD:**

Operation on paved surfaces such as sidewalks, trails, parking lots, or public highways and streets.

#### **WHAT CAN HAPPEN:**

All-terrain tires are designed for off-road use. Driving on paved surfaces greatly affects how a vehicle handles, which can result in loss of control and/or an accident.

#### **HOW TO AVOID THE HAZARD:**

Never drive on paved surfaces. If it is unavoidable, slow down and do not make sudden turning or braking maneuvers.

Never operate on public highways or streets if it is not allowed by law. Check local laws to determine if it is legal to do so.

## OPERATOR SAFETY

### **⚠️ WARNING**

#### **POTENTIAL HAZARD:**

Operating this vehicle without wearing approved helmet, eye protection, and protective clothing.

#### **WHAT CAN HAPPEN:**

Operating without an approved helmet increases the risk of a severe head injury or death in the event of an accident. Operating without eye protection could result in an accident and could increase the chance of a severe eye injury in the event of an accident. Operating without protective clothing could increase the chance of a severe injury.

#### **HOW TO AVOID THE HAZARD:**

Always wear an approved helmet that fits properly. Always wear eye protection (goggles or face shield), gloves, long-sleeved shirt or jacket, long pants, and over-the-calf boots.

### **⚠️ WARNING**

#### **POTENTIAL HAZARD:**

Operating the vehicle after consuming alcohol or drugs.

#### **WHAT CAN HAPPEN:**

Consumption of alcohol and/or drugs could seriously affect operator judgment. Reaction time may be slower and operator balance and perception could be affected. Consumption of alcohol and/or drugs before or while operating a vehicle could result in an accident causing severe injury or death.

#### **HOW TO AVOID THE HAZARD:**

Never consume alcohol or drugs before or while operating the vehicle.



## OPERATOR SAFETY

### WARNING

#### **POTENTIAL HAZARD:**

Operating at excessive speeds.

#### **WHAT CAN HAPPEN:**

Excessive speed increases the operator's chance of losing control, which can result in an accident.

#### **HOW TO AVOID THE HAZARD:**

Always operate at a speed that's proper for the terrain, visibility and operating conditions, and your experience.

### WARNING

#### **POTENTIAL HAZARD:**

Attempting slides, jumps, and other stunts.

#### **WHAT CAN HAPPEN:**

Attempting stunts increases the chance of an accident, including an overturn.

#### **HOW TO AVOID THE HAZARD:**

Never attempt slides, jumps, or other stunts.

## OPERATOR SAFETY

### **WARNING**

#### **POTENTIAL HAZARD:**

Failure to inspect the vehicle before operating. Failure to properly maintain the vehicle.

#### **WHAT CAN HAPPEN:**

Poor maintenance increases the possibility of an accident or equipment damage.

#### **HOW TO AVOID THE HAZARD:**

Always inspect your vehicle before each use to make sure it's in safe operating condition.

Always follow the inspection and maintenance procedures and schedules described in the owner's manual.

### **WARNING**

#### **POTENTIAL HAZARD:**

Extending arms, hands, or legs outside the ROPS bars of the vehicle during operation.

#### **WHAT CAN HAPPEN:**

Severe injury can occur to arms, hands, or legs if the vehicle overturns or rolls over in an accident.

#### **HOW TO AVOID THE HAZARD:**

Always keep arms, hands, or legs inside the vehicle, hands on the steering wheel or hand grip, and keep both feet on the floorboards of the vehicle during operation.

## OPERATOR SAFETY

### WARNING

#### **POTENTIAL HAZARD:**

Failure to use extra caution when operating on unfamiliar terrain.

#### **WHAT CAN HAPPEN:**

Unfamiliar terrain may contain hidden rocks, bumps, or holes that could cause loss of control or overturn.

#### **HOW TO AVOID THE HAZARD:**

Travel slowly and use extra caution when operating on unfamiliar terrain. Always be alert to changing terrain conditions.

### WARNING

#### **POTENTIAL HAZARD:**

Turning improperly.

#### **WHAT CAN HAPPEN:**

Improper turns could cause loss of control and lead to a collision or overturn.

#### **HOW TO AVOID THE HAZARD:**

Always follow proper procedures for turning as described in the owner's manual. Practice turning at slow speeds before attempting to turn at faster speeds. Never turn at excessive speed.

## OPERATOR SAFETY

### **WARNING**

#### **POTENTIAL HAZARD:**

Failure to use extra caution when operating on excessively rough, slippery or loose terrain.

#### **WHAT CAN HAPPEN:**

Operating on excessively rough, slippery or loose terrain could cause loss of traction or loss of control, which could result in an accident or overturn.

#### **HOW TO AVOID THE HAZARD:**

Do not operate on excessively rough, slippery or loose terrain until you've practiced and learned the skills necessary to control the vehicle on such terrain. Always use extra caution on rough, slippery or loose terrain.

### **WARNING**

#### **POTENTIAL HAZARD:**

Climbing excessively steep hills or climbing hills improperly.

#### **WHAT CAN HAPPEN:**

Improper hill climbing could cause loss of control or overturn.

#### **HOW TO AVOID THE HAZARD:**

Never operate on hills too steep for the vehicle or for your abilities. Practice on smaller hills before attempting large hills. Always check the terrain carefully before ascending any hill. Never climb hills with excessively slippery or loose surfaces. Never increase the throttle suddenly while traveling uphill. The vehicle could flip over backwards. Never go over the top of any hill at high speed. An obstacle, a sharp drop, another vehicle, or person could be on the other side of the hill.

## OPERATOR SAFETY

### **WARNING**

#### **POTENTIAL HAZARD:**

Traveling down excessively steep hills.

#### **WHAT CAN HAPPEN:**

Improper downhill travel could cause loss of control or overturn.

#### **HOW TO AVOID THE HAZARD:**

Never operate on hills too steep for the vehicle or for your abilities. Practice on smaller hills before attempting large hills. Always check the terrain carefully before attempting any hill. Never descend hills with excessively slippery or loose surfaces.

#### **NOTE:**

Always check the terrain carefully before descending a hill. Never travel down a hill at high speed. Avoid traveling down a hill at an angle. Travel straight down the hill when possible.

## OPERATOR SAFETY

### WARNING

#### **POTENTIAL HAZARD:**

Improperly crossing hills and turning on hills.

#### **WHAT CAN HAPPEN:**

Improperly crossing or turning on hills could cause loss of control or overturn.

#### **HOW TO AVOID THE HAZARD:**

Use extra caution when turning on any hill. Avoid crossing the side of a steep hill.

#### **WHEN CROSSING THE SIDE OF A HILL:**

Always follow proper procedures as described in the owner's manual. Avoid hills with excessively slippery or loose surfaces.

## OPERATOR SAFETY

### WARNING

#### **POTENTIAL HAZARD:**

Stalling, rolling backwards while climbing a hill.

#### **WHAT CAN HAPPEN:**

The vehicle could overturn.

#### **HOW TO AVOID THE HAZARD:**

Maintain a steady speed when climbing a hill.

#### **IF ALL FORWARD SPEED IS LOST:**

Close the throttle. Apply the brake. When fully stopped, shift the gear selector to the park position.

#### **IF THE VEHICLE BEGINS ROLLING:**

Never apply engine power. Carefully apply the foot brake while rolling backwards. When fully stopped, keep the brake applied, shift the gear selector to the parking position, and determine the best way to safely change direction.

## OPERATOR SAFETY

### WARNING

#### **POTENTIAL HAZARD:**

Improperly operating over obstacles.

#### **WHAT CAN HAPPEN:**

Operating over obstacles could cause loss of control or overturn.

#### **HOW TO AVOID THE HAZARD:**

Before operating in a new area, check for obstacles. Avoid operating over large obstacles such as rocks and fallen trees when possible. If unavoidable, use extreme caution and always follow proper procedures as outlined in the owner's manual.

### WARNING

#### **POTENTIAL HAZARD:**

Skidding or sliding.

#### **WHAT CAN HAPPEN:**

Skidding or sliding can cause loss of control. If the tires regain traction unexpectedly, the vehicle could overturn.

#### **HOW TO AVOID THE HAZARD:**

On slippery surfaces such as ice, travel slowly and use extra caution to reduce the chance of skidding or sliding out of control.

## OPERATOR SAFETY

### **WARNING**

#### **POTENTIAL HAZARD:**

Overloading the vehicle or carrying/towing cargo improperly.

#### **WHAT CAN HAPPEN:**

Overloading and towing can cause changes in vehicle handling, which could lead to loss of control or an accident.

#### **HOW TO AVOID THE HAZARD:**

Never exceed the stated load capacity for this vehicle.

Cargo should be properly distributed and securely attached. Reduce speed and always use low gear when carrying cargo or pulling a trailer. Allow a greater distance for braking. Always follow the instructions in the owner's manual for carrying cargo or pulling a trailer.

## OPERATOR SAFETY

### WARNING

#### **POTENTIAL HAZARD:**

Operation the vehicle through deep or fast-flowing water.

#### **WHAT CAN HAPPEN:**

Tires may float, causing loss of traction and loss of control, which can lead to an accident or overturn.

#### **HOW TO AVOID THE HAZARD:**

Avoid operating through deep or fast-flowing water. If it is unavoidable to enter water that exceeds the recommended maximum depth, travel slowly, balance your weight carefully, avoid sudden movements, and maintain a slow and steady forward motion. Do not make sudden turns or stops, and do not make sudden throttle changes. Wet brakes may have reduced stopping ability. Always test the brakes after leaving the water. If necessary, apply the brakes several times while driving slowly to dry out the pads.

## OPERATOR SAFETY

### WARNING

#### **POTENTIAL HAZARD:**

Improperly operating in reverse.

#### **WHAT CAN HAPPEN:**

The vehicle could collide with an obstacle or person, resulting in severe injury.

#### **HOW TO AVOID THE HAZARD:**

Before shifting into reverse gear, always check for obstacles or people behind the vehicle. When it's safe to proceed, back slowly.

### WARNING

#### **POTENTIAL HAZARD:**

Operating this vehicle with improper tires, or with improper or uneven tire pressure.

#### **WHAT CAN HAPPEN:**

Use of improper tires, or operation of the vehicle with improper or uneven tire pressure, could cause loss of control or an accident.

#### **HOW TO AVOID THE HAZARD:**

Always use the size and type of tires specified in the owner's manual. Always maintain proper tire pressure.

## OPERATOR SAFETY

### **WARNING**

#### **POTENTIAL HAZARD:**

Operating the vehicle with improper modifications.

#### **WHAT CAN HAPPEN:**

Improper installation of accessories or modification of the vehicle may cause changes in handling which could lead to an accident.

#### **HOW TO AVOID THE HAZARD:**

Never modify the vehicle through improper installation or use of accessories. All parts and accessories added to the vehicle must be genuine parts or equivalent components designed for use on this vehicle, and they should be installed and used according to approved instructions. Consult your dealer for more information.

### **WARNING**

#### **POTENTIAL HAZARD:**

Operating on frozen bodies of water.

#### **WHAT CAN HAPPEN:**

Severe injury or death can result if the vehicle falls through the ice.

#### **HOW TO AVOID THE HAZARD:**

Never operate the vehicle on the frozen water.

## OPERATOR SAFETY

### WARNING

Leaving the NFC key in the vehicle can lead to unauthorized use, resulting in serious injury or death. Always remove the NFC key when the vehicle is not in use.

### WARNING

After any overturn or accident, have an authorized dealer inspect the entire vehicle for possible damage, including (but not limited to): ROPS, brakes, throttle and steering systems.

### WARNING

Safe operation of this vehicle requires good judgment and physical skills. Persons with cognitive or physical disabilities who operate this vehicle have an increased risk of overturn and loss of control, which could result in severe injury or death.

### WARNING

Exhaust system components are very hot during and after use of the vehicle. Hot components can cause serious burns and fire. Do not touch hot exhaust system components. Always keep combustible materials away from the exhaust system. Use caution when traveling through tall grass, especially dry grass.

## CONTROLS & FEATURES

### Vehicle Feature Locations and Descriptions

Z10

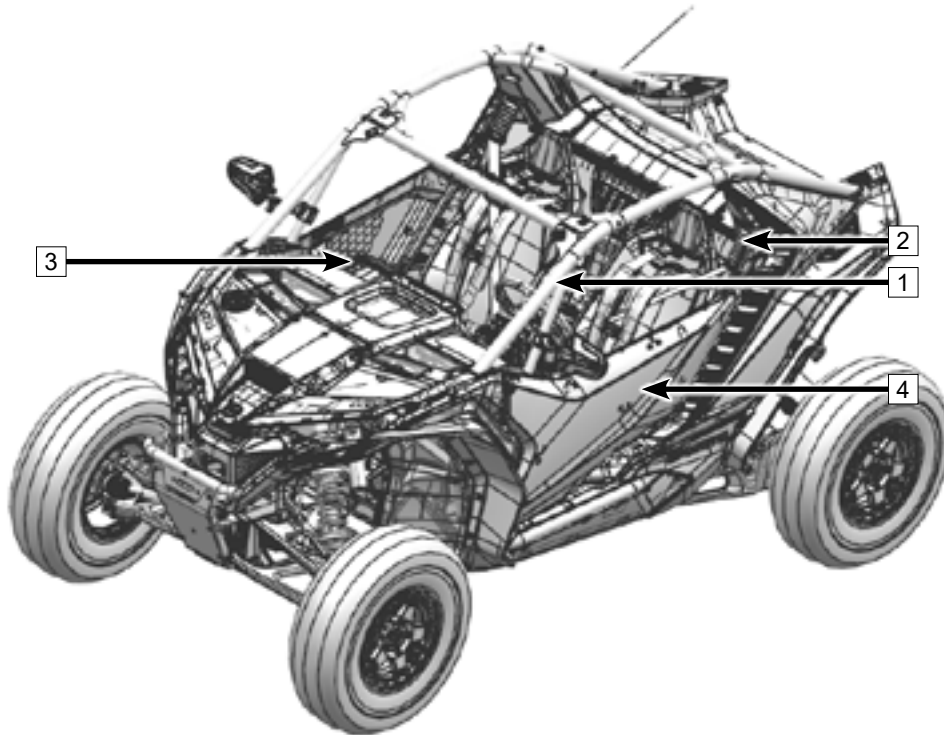

## CONTROLS & FEATURES

Z10

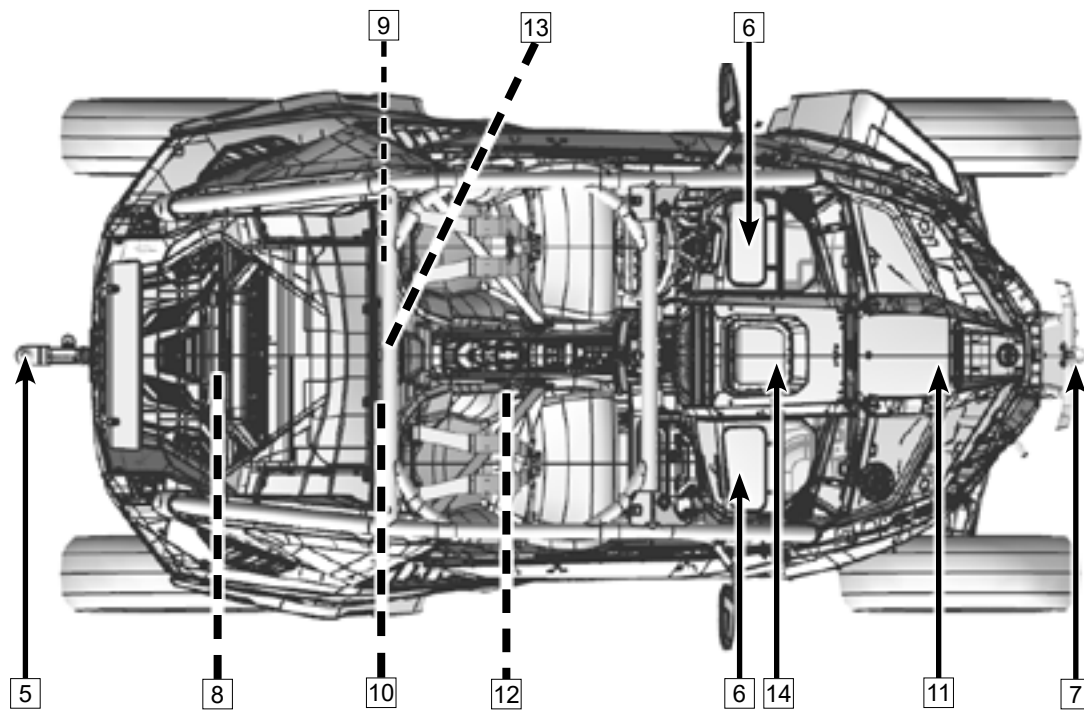

## CONTROLS & FEATURES

Z10-4

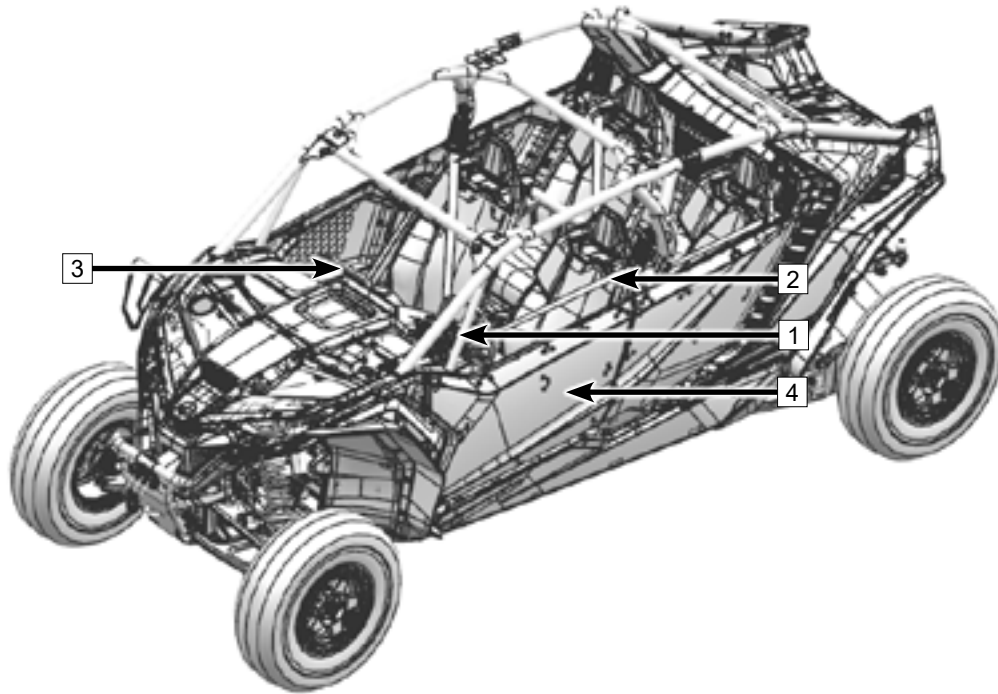

# CONTROLS & FEATURES

Z10-4

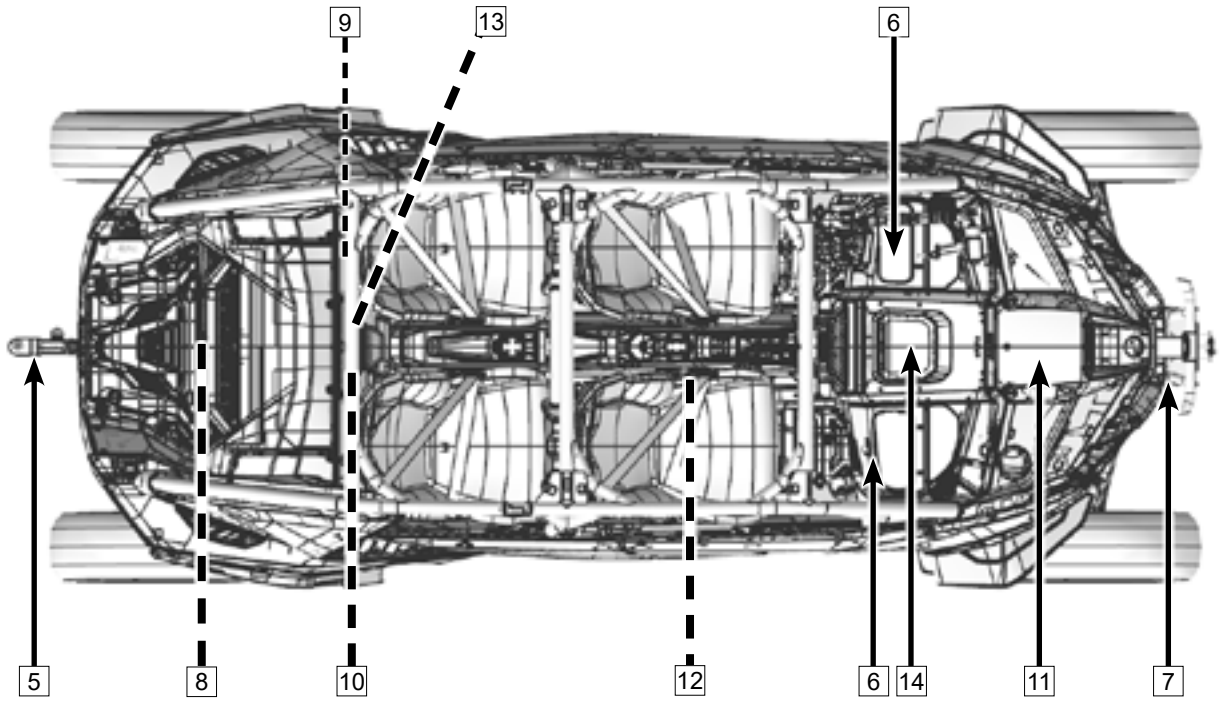

## CONTROLS & FEATURES

### Controls and Features

#### **Roll Over Protection System (ROPS) - (1)**

This vehicle is equipped with cab frame to help to protect the occupants from injury in case of a rollover or other dangerous situation. Never place any body part outside of the cab frame while the vehicle is moving.

#### **Safety Belt - (2)**

This vehicle is equipped with seat belts to help keep occupants in the cab and protect the driver and passenger in the event of a collision, rollover or tip-over. A seat belt indicator light will flash if the seat belt is not fastened during driving.

#### **Passenger Handrail - (3)**

A handrail is provided in the front of the passenger seat. Holding the handrail allows the passenger to brace against the movement of the vehicle and keep the hands and body inside the cab in case of rollover.

#### **NOTE:**

**When carrying a passenger, the operator should instruct the passenger to hold the handrail tightly at all times.**

#### **Side Door - (4)**

The vehicle is equipped with side doors to protect the driver and passenger in the cab. Always latch side doors when driving the vehicle. Make sure the side door mounting points are fixed securely on the vehicle and buckle the latch into the lock connector.

## CONTROLS & FEATURES

### Hitch Receiver - (5 - If equipped)

This vehicle is equipped with a 2 x 2 in. (51 x 51 mm) standard hitch receiver. Trailer light socket and cable adapter are located at the rear of the vehicle. If there is no 7-pin connector, an additional trailer socket and power adapter are required. Please consult with your dealer on towing and the use of trailers before using your vehicle.

### Trailer Power Socket (If equipped)

This vehicle is equipped with a trailer power socket, located at the rear of the vehicle, which requires a wiring adapter. The trailer power socket is configured to the standard shown in the image.

#### NOTE

The power range of the trailer power socket for trailer position and turning lights is 1W~21W.

CFMOTO recommends purchase of a trailer within the power range to avoid trailer position and turning lights not working properly (when equipped - select markets).

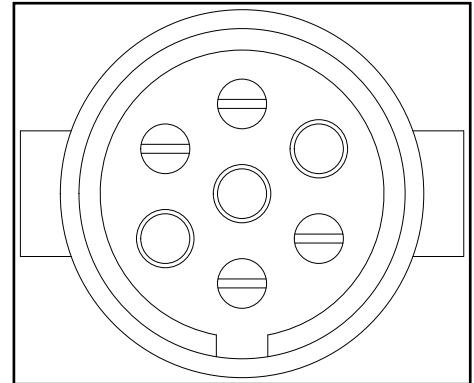
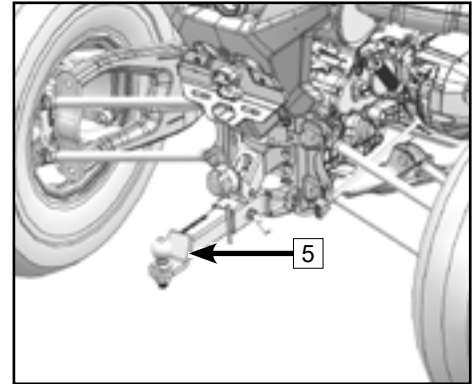

## CONTROLS & FEATURES

### Driver/Passenger Storage Box - (6)

The vehicle is equipped with sealed storage boxes on both sides of the dashboard upper body for storing lightweight items.

### Winch - (7- If equipped)

This vehicle is equipped with a 4500-lb winch. To preserve battery power, only operate the winch while the engine is running. Please refer to the winch operation section of this manual for further information or consult with your dealer on the use of the winch before using your vehicle.

### Rear Access Cover - (8)

Before removing the rear access cover, remove the rear seat and the front access cover.

With the rear access cover removed, certain parts of the engine can be inspected or repaired.

Removal: Remove the two plastic clasps **1** on the rear access cover, and pull forward and remove.

Installation: Align the rear access cover tab **2** with the corresponding holes, and then install the plastic clasps.

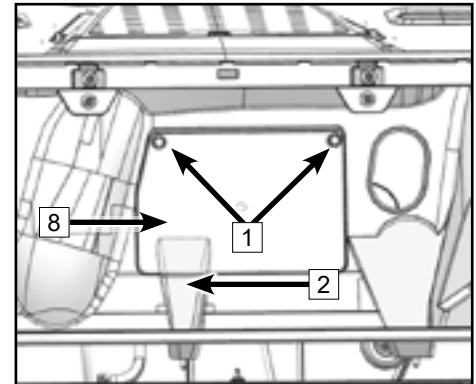

## CONTROLS & FEATURES

### Air Filter Access Cover - (9)

The air filter access cover is located behind the driver seat (Z10-4 location is behind the left rear passenger seat). Release the clasps **1**, take out the air filter access cover upward and remove the air filter cover. The air filter can be cleaned and serviced.

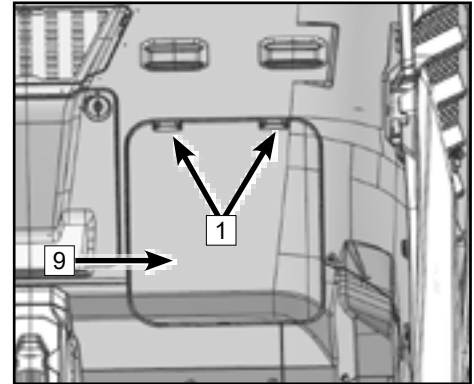

### Lower Service Cover - (10)

The lower service cover is located behind the passenger seat (Z10-4 location is behind the right rear passenger seat). With the lower service cover removed, the ECU, ECU diagnostic port, and fuse box can be accessed.

Removal: Remove the passenger seat (Z10-4, remove the right rear passenger seat), turn the knobs **1** to the unlock state, then pull out the service cover upward.

Installation: Install the tabs of the service cover into the corresponding holes, and then turn the knob **1** to lock state.

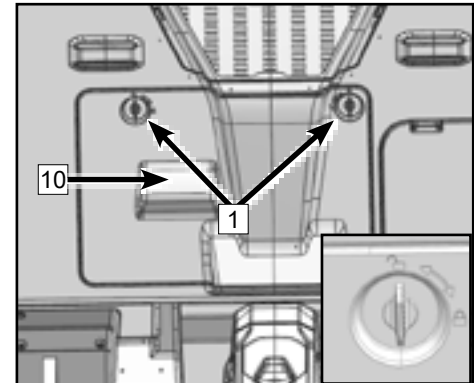

## CONTROLS & FEATURES

### Front Top Cover - (11)

Remove the front top cover when inspection and maintenance are required for the water tank, brake fluid reservoir, and winch relay.

Removal: Release the clasp **1**, pull upward to release the top grommet pins, then slide the cover forward to release the alignment tabs and bottom grommet pins to remove.

Installation: Insert the cover tabs into the corresponding holes on the body, then align the bottom and top grommet pins and press down.

#### NOTE:

Maintain easy cover removal by applying a small amount of lubricant to the grommet pins occasionally.

### Gearshift Access Panel - (12)

When adjustment is required for gearshift, remove the passenger seat and gearshift access panel (Z10-4, remove the the front passenger seat and the gearshift access panel).

Removal: Remove the passenger seat, release the clasps **1**, pull upward to remove the panel.

Installation: Insert the tabs into the corresponding holes on the body, then press down at the clasps **1** to secure the panel.

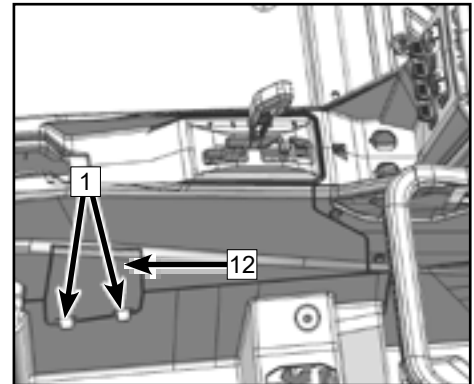
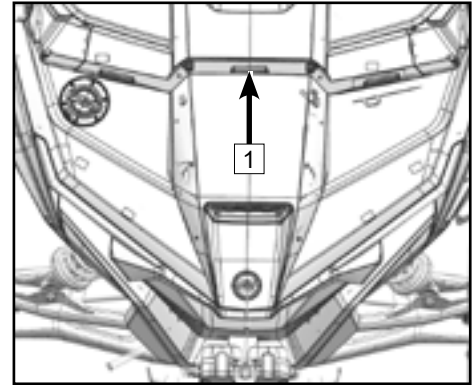

## CONTROLS & FEATURES

### Upper Service Cover - (13)

Remove the upper service cover when the cooling system components require inspection or repair.

Removal: Release the clasps **1**, and pull upward to remove.

Installation: Insert the panel upper service cover tab into the corresponding holes, then press the clasps **1** tightly.

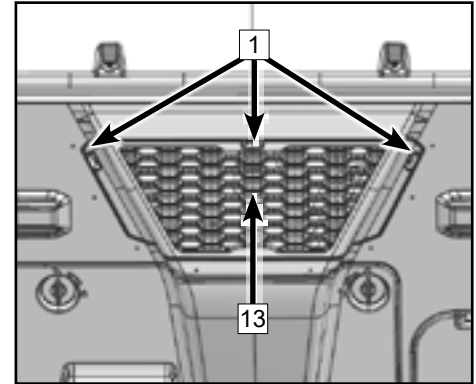

### Fuel Pump Access Cover - (14)

Fuel pump service cover is located in the center of the front body panel. Remove the fuel pump access cover to inspect the fuel tank, fuel pump, and fuel lines.

Removal: Grasp the cover edge, then pull upward to release the tabs and remove.

Installation: Insert the tabs into the corresponding holes of the body, then align the remaining tabs and press.

### NOTE:

Maintain easy cover removal by applying a small amount of lubricant to the grommet pins occasionally.

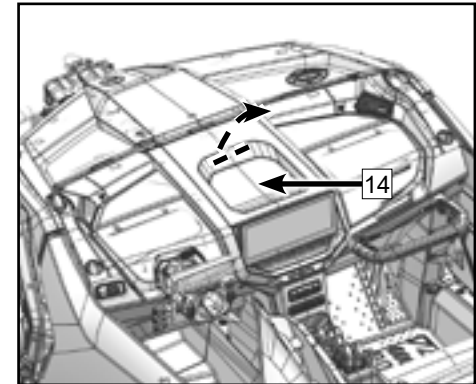

## CONTROLS & FEATURES

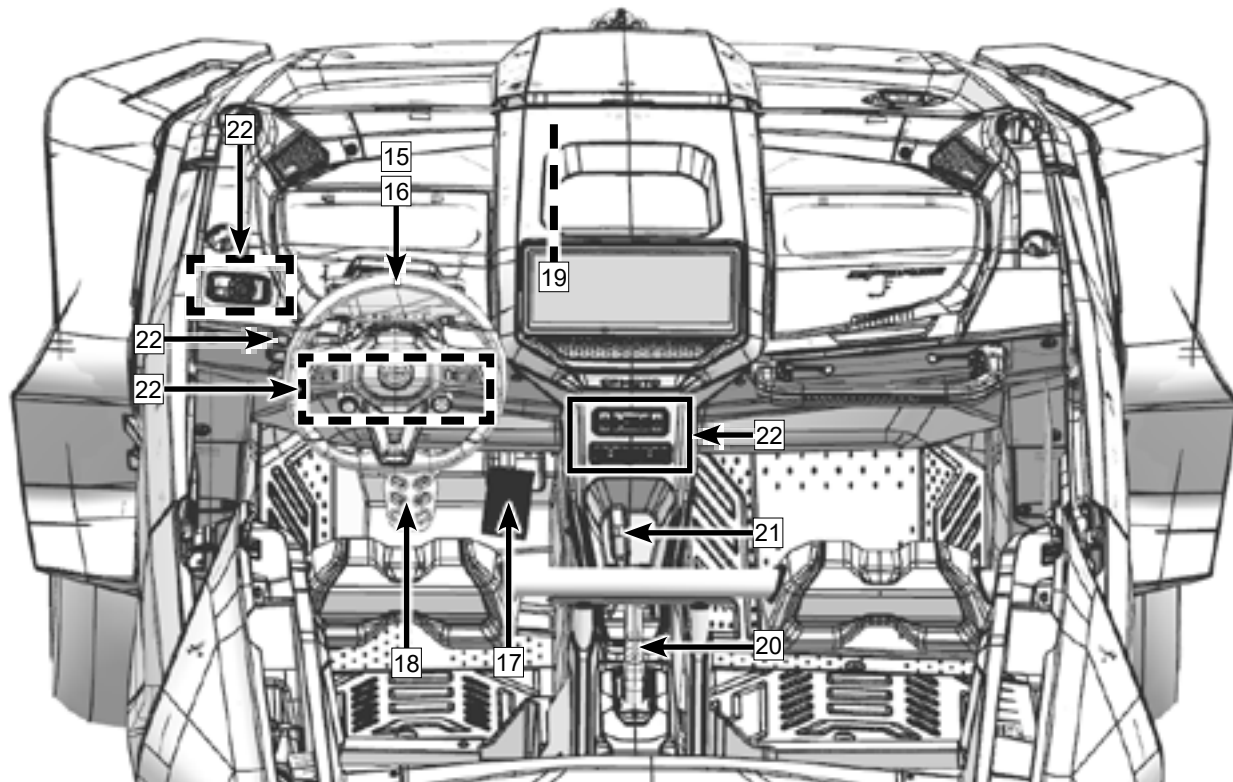

## CONTROLS & FEATURES

### Primary Controls

#### Tilt Lever and Steering Wheel Lock - (15)

A tilt lever feature allows the steering wheel to be adjusted to fit the operator. Pull up the lever and adjust the steering wheel tilt angle for comfort. Release the lever, the lever will automatically return to lock the steering wheel angle.

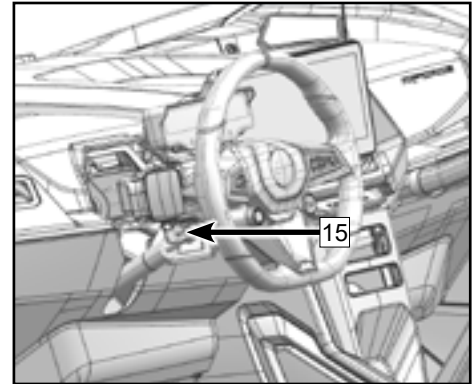

#### Steering Wheel - (16)

The steering wheel is located in front of the driver's seat. Use the steering wheel to turn the vehicle left or right to the desired direction of travel.

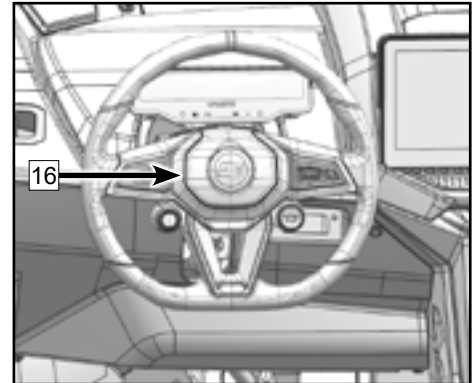

## CONTROLS & FEATURES

### Electronic Throttle Pedal - (17)

The electronic throttle pedal is located to the right of the brake pedal. The throttle pedal controls engine rpm and vehicle speed by pressing the pedal with your right foot. Always check the pedal function before driving.

The electronic throttle system has the following functions:

1. Start protection function: Before the vehicle starts, step on the brake before starting the vehicle.
2. Reverse speed limit function: The vehicle speed is limited to 19 mph (25 km/h) while operating in reverse gear.
3. Idling function: When the vehicle is in Neutral, engine RPM is limited to 5000rpm.
4. Brake priority function: When the driver applies both brake pedal and throttle pedal at the same time, the electronic throttle body will close. The engine returns to idle automatically.
5. Limp home function: When a fault of the electronic throttle body or throttle pedal is detected, the system will enter into torque limitation or limp home mode.

### Brake Pedal - (18)

The brake pedal is located at the left side of throttle pedal. Release throttle pedal and apply brake pedal to reduce speed or stop the vehicle.

Brake pedal start protection function: whether it is to start the vehicle or switch gears, the brake pedal must be pressed in advance to perform subsequent operations.

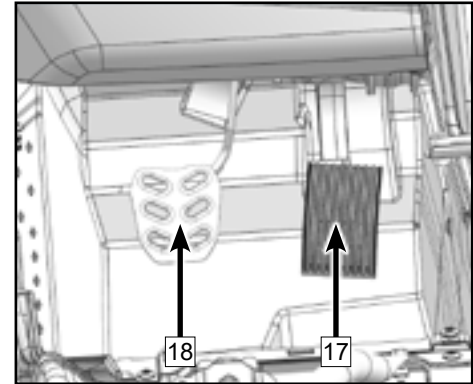



## CONTROLS & FEATURES

### Telematics Box - (19 - If equipped)

This vehicle is equipped with an intelligent vehicle terminal box located on the right side of the driver's front storage box that builds a communication bridge between the owner and vehicle through the CFMOTO RIDESYNC APP installed on a mobile device. The CFMOTO RIDESYNC APP is available for download from the Apple App Store for iPhone or Google Play for Android.

### Hand Brake - (20 - If equipped)

This vehicle is equipped with an auxiliary hand brake, which is located on the right side of the driver seat. Pull the lever back to apply the rear brakes, the parking indicator  on the dashboard turns on and prevents the vehicle from rolling when parked on an incline.

To release the hand brake, pull the handle lever slightly and depress the release button at the end of the lever, then push the lever down to its original position. The parking indicator  on the dashboard turns off.

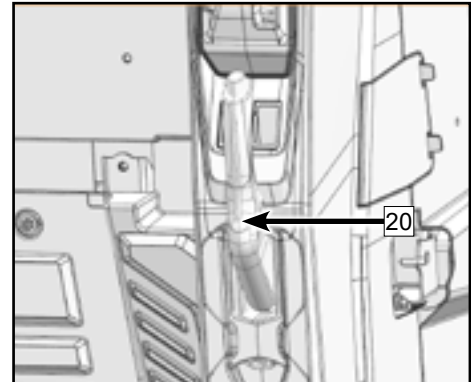
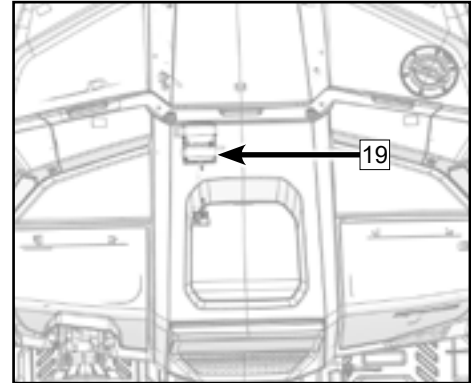

### CAUTION

**Never depend on the transmission parking feature alone if the vehicle is parked on a hill. Always apply the hand brake and block the wheels on the downhill side of the vehicle to prevent movement. It is recommended to park the vehicle on level ground.**

**If the vehicle is moving and the hand brake is not released completely, the speed will be limited to 7 mph (10 km/h).**

## CONTROLS & FEATURES

### Gear Shift Lever - (21)

The gear shift lever is located to the right of the driver seat. It is used for changing the transmission gear selection:

When shifting gears, the throttle should be closed and the vehicle should be stopped. Do not shift gears while the vehicle is at speed.

**L** – Low Gear. The low speed range of the gearbox. It allows the vehicle to move slowly with maximum torque at the wheels.

**NOTE: To avoid damage to the CVT system, use low gear when constant slow speeds will be; less than 19 mph (30 kph), pulling a trailer, carrying heavy cargo, going over obstacles, or driving up and down steep hills.**

**H** – High Gear. The high speed range of the gearbox. It allows the vehicle to reach its maximum speed. Use when driving speeds will be over 19 mph (30 km/h).

**N** – Neutral. In neutral position the engine power output is disengaged.

**R** – Reverse. The reverse gear allows the vehicle to go backwards. The top speed is limited to 19 mph (30 km/h) in reverse.

**P** – Park. The park position locks the gearbox to help prevent vehicle movement.

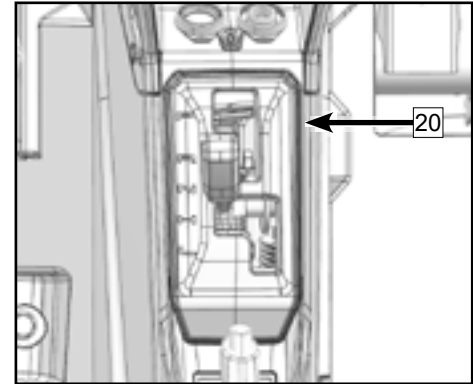

### NOTE

In reverse operation, the engine's RPM is limited to a vehicle speed under 19 mph (25 km/h).

### WARNING

**Use extreme caution driving downhill in reverse. Gravity can increase the vehicle speed above the set limited reverse speed.**

**Always shift to PARK (P) position when the vehicle is not in operation. The vehicle can roll if the shift lever is not set to 'P'.**

## CONTROLS & FEATURES

### Secondary Controls

#### Switch Panel - (22)

#### Dimmer Switch / Auxiliary Light Switch 1, 2

Dimmer rotary switch consists of three positions. Choose the desired button according to the function icons:

	When the switch is on this position, position light/tail light, and low beam light turn on.
	When the switch is on this position, position light/tail light, low beam light and high beam light turn on.
	When the switch is on this position, only the position light is on, and other lights turn off.
	Reserved light switch (additional accessory installation)
	Reserved light switch (additional accessory installation)

#### NOTE

The vehicle must be powered on to operate head lights.

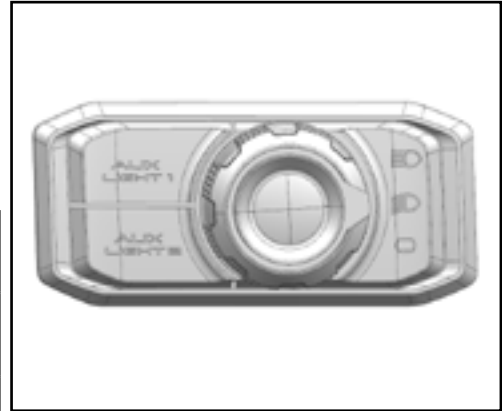

#### CAUTION

Do not use the headlights with the engine turned off for more than 15 minutes. The battery may discharge to a point that the starter motor will not operate properly. If this should happen, remove the battery and recharge it.



## CONTROLS & FEATURES

### Steering Wheel Controls

The steering wheel has five controls. Choose the control according to the desired function:

1	Suspension control switch	3	Volume adjustment switch	5	START/STOP switch
2	VR button	4	Mode switch		

### Suspension Control Switch - 1

	Dial up: The suspension mode is Soft-Medium-Firm in order. When the suspension mode is Firm, continuing to press dial up the mode will not change.
	Dial down: The suspension mode is Firm-Medium-Soft, When the suspension mode is Soft, continuing to press dial down the mode will not change.

### Voice Recognition (VR) Switch - 2

Short press: Activates / Turns off VR voice.

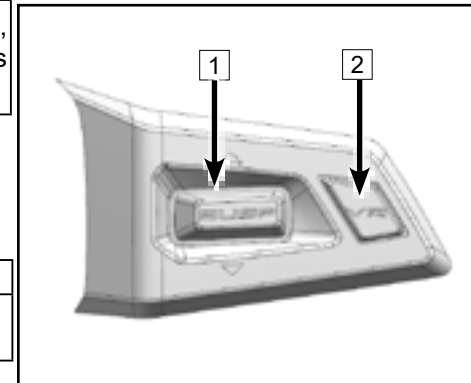
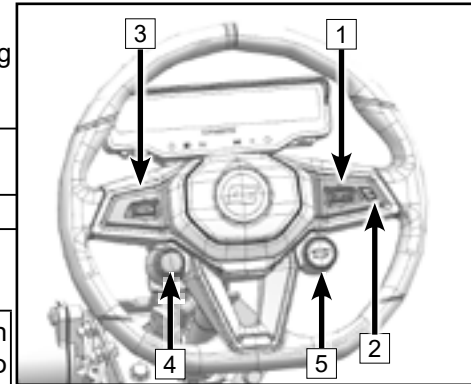

Long press: Activates VR voice.

<b>NOTE</b>
VR function can be used after a helmet with Bluetooth communications is connected.



## CONTROLS & FEATURES

### Volume Adjustment Switch - 3

	When pressing the switch to this position, the volume increases.
	When pressing the switch to this position, the volume decreases.

### Suspension Mode Switch - 4

Rotate the suspension mode switch to switch between these functions:

**COMFORT Mode:** When the vehicle is in "COMFORT" mode, the vehicle will have a less aggressive throttle response for smooth starts and is intended for flat trails, hard pack ground. etc. Use for light-duty riding.

#### CAUTION

**Do not use comfort mode for driving situations that place high load on the CVT belt. Damage may occur.**

**TRAIL Mode:** When the vehicle is "TRAIL" mode, the vehicle will have a moderately aggressive throttle response.

**SPORT Mode:** When the vehicle is in "SPORT" mode, the vehicle will have a faster, aggressive throttle response.

**NOTE: Sport mode is intended for work loads, complex terrain or trails, and other driving situations that can place a high load on the CVT belt.**

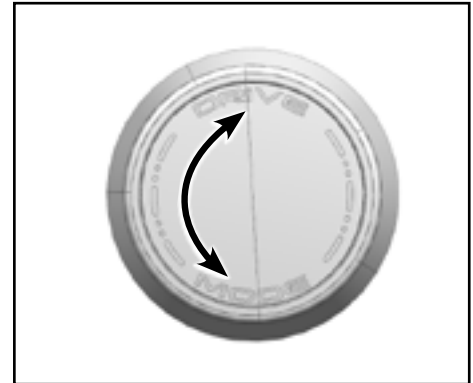
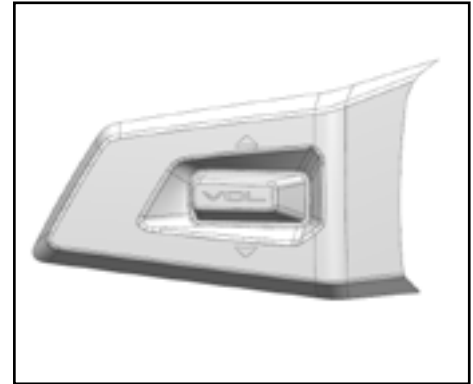

## CONTROLS & FEATURES

### Key Slot / NFC Key / START-STOP Switch-5

The key slot [1] is located at the right side of the steering wheel, a bar groove for holding the NFC key.

The NFC key [2] is required for starting the vehicle.

START/STOP switch [5], the ignition switch for starting and stopping the engine. Also used for power-on only.

### Start the Engine

Insert the NFC key [2] into the key slot [1], press the brake pedal, and press the "START/STOP" button until the engine starts.

### Stop the Engine

Stop the vehicle. With the engine at idle, press the brake pedal with your foot and press the "START/STOP" button [5] to stop the engine.

### Vehicle Power 'ON' only:

Insert the NFC key [2] into the slot [1] and press the "START/STOP" button [5] without pressing the brake pedal. The vehicle will power on but the engine does not start, the instrument panel activates, and electronic equipment such as the sound system, lighting, etc. is available. Press the "START/STOP" button again to turn off the vehicle power.

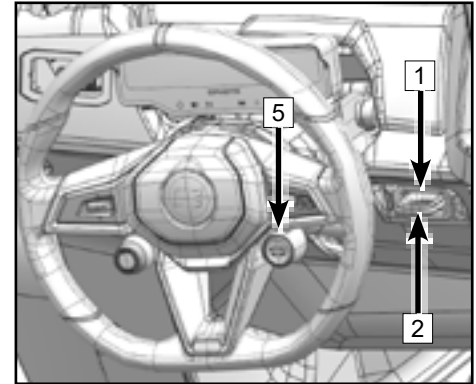

## **CONTROLS & FEATURES**

To avoid loss of battery power when the vehicle is powered on for a long time without starting the engine, the vehicle will automatically power off after 10 minutes when the entertainment system is not operating. Before the automatic power down, the MMI will prompt 30 seconds in advance by a pop-up window, and the user can choose to delay the power down during this period.

### **NFC Key Pairing**

Contact your CFMOTO dealer for any of the following NFC key issues:

1. If the NFC key does not allow the vehicle to be powered on or started.
2. If the vehicle is paired with one NFC key and another needs to be added.
3. If the vehicle is paired with one NFC key and one is lost.
4. If the vehicle is paired with two NFC keys and both are lost.



In most instances, new NFC keys can be purchased and programmed at your CFMOTO dealer.

## CONTROLS & FEATURES

### Combination Switch (If equipped)

(If equipped - Select Markets)

### Turning Lights (If equipped)

	Lift up in the arrow direction <b>A</b> beyond the point of resistance to activate right turning light flashing. The indicator will flash on the instrument. Toggle the combination switch in reverse to cancel the right turning light.
	Push down in the arrow direction <b>B</b> beyond the point of resistance to activate left turning light flashing. The indicator will flash on the instrument. Toggle the combination switch in reverse to cancel the left turning light.

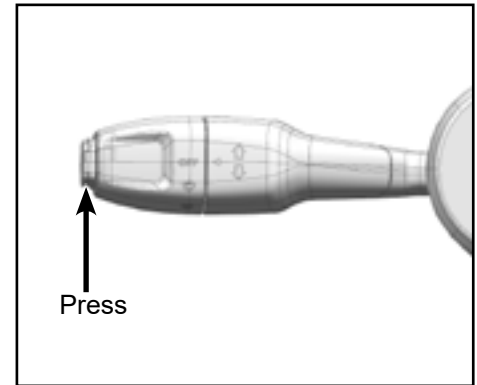
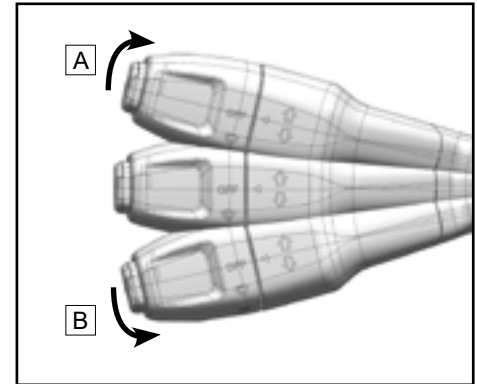



### Horn Switch (If equipped)

	Press the icon button to sound the horn. Release the icon button to turn off the horn.
---	--

## CONTROLS & FEATURES

### Wiper Control Knob (If equipped)



Rotate the knob in the arrow direction to align the icon “” with “” to turn on and operate the wiper. Rotate the knob in reverse, and align “OFF” with “” to turn off the wiper.

#### NOTE

In a cold environments, wipe off snow, frost or other debris from the windshield, wiper arm and wiper blade before turning on the wiper.

Do not use the wiper in extremely dry conditions. Ensure that the wiper is not stuck in extremely hot or cold conditions.

### Front Windshield Cleaning (If equipped)

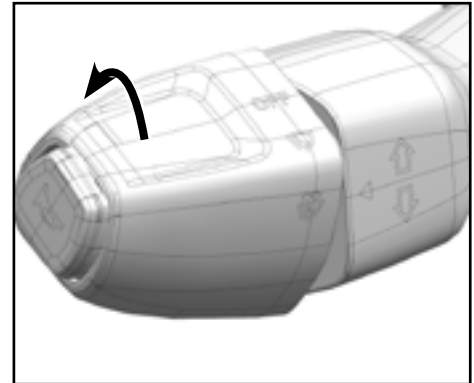
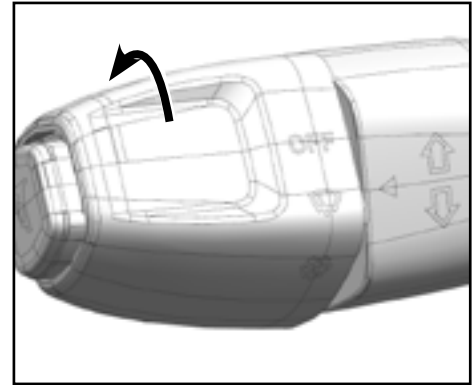

Rotate the knob in the arrow direction to align the icon “” with “” to active wiping while spraying from the wiper blade. Rotate the knob in reverse and align “OFF” with “”. The washer stops spraying water, cleaning is over, and wiping stops.



## CONTROLS & FEATURES

### 2WD / 4WD Switch

This vehicle is equipped with an on-command “2X4”/“4X4” and an optional front diff-lock/diff-unlock “4WD-LOCK”/“4WD-UNLOCK” switch panel, located under the Ridesync MMI. Select the appropriate drive mode according to terrain and conditions:



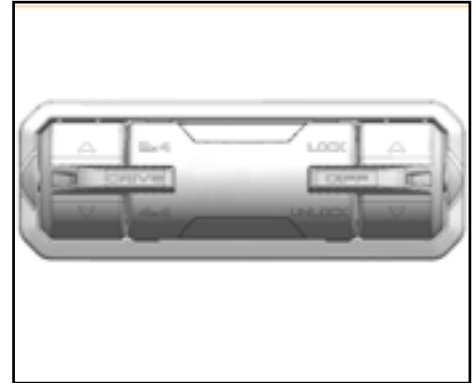

	2WD - When the switch is on this position, power is supplied to the rear wheels only.
	4WD - When the switch is on this position, power is supplied to both front and rear wheels.
LOCK	4WD-LOCK - When the switch is on this position, power is supplied to the rear and front wheels, and the front differential is locked. Unlike 4WD mode, all wheels turn at the same speed.



## CONTROLS & FEATURES



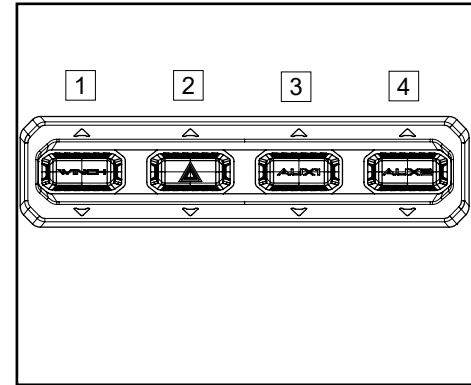

### Function Switch Panel

The vehicle is equipped with a function switch panel located below the 2WD / 4WD switch:

	Winch switch (1- If equipped)
	Hazard warning switch (2- If equipped)
	Reserved switch position (3)
	Reserved switch position (4)



### **Winch Switch (If equipped)-1**

	When the vehicle is powered on or the engine starts, lift the switch to this position "  ". The winch cable will extend outward.
	When the vehicle is powered on or the engine starts, press the switch to this position "  ". The winch cable will retract inward.

### **Hazard Warning Switch (If equipped)-2**

When the hazard warning switch is in use, the front and rear turning lights will flash. At the same time, the hazard switch indicator on the instrument will light up.

## CONTROLS & FEATURES

Z10

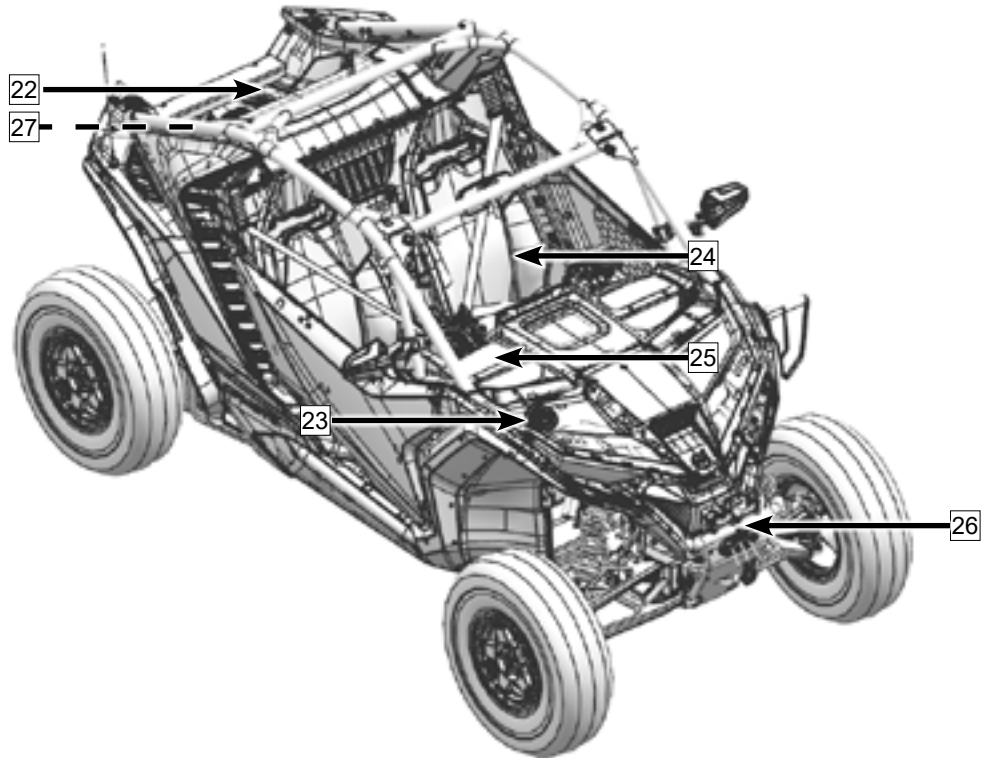

## CONTROLS & FEATURES

Z10-4

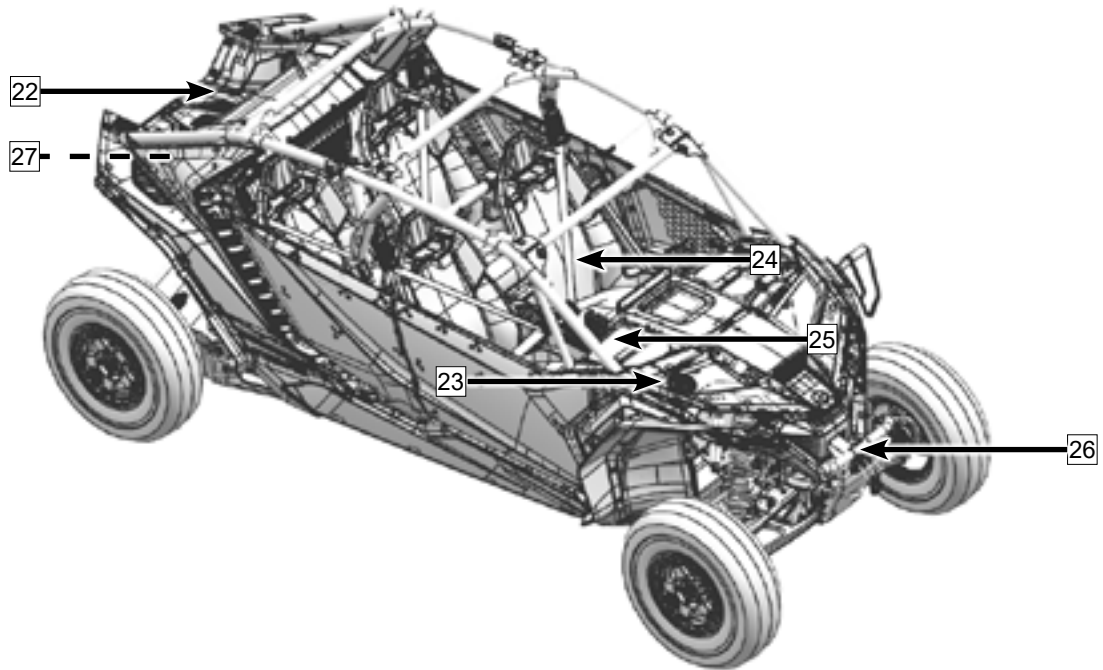

## CONTROLS & FEATURES

### Other Features

#### Cargo Box - (22)

This vehicle is equipped with a cargo box to carry a small amount of items which can be secured by straps or ropes.

#### Fill cap - (23)

The fuel tank fill cap is located in the middle of the front right panel of the vehicle. To fill the tank, grasp the fuel cap firmly, then turn counter-clockwise and remove it. Reinstall the fuel cap securely after filling is completed. Fuel tank volume is 11.88 gallons (45 L).

#### Driver and Passenger Seats - (24)

The driver's seat offers adjustment (Z10-4 , the front driver seat and passenger seat offer fore and aft adjustment). To adjust the seat, turn the lever upward to unlock it. Release the lever to lock the seat into the desired position.

The passenger's seat can be removed (Z10-4 , two passenger seats in the second row can be removed, the rest of the seats cannot be removed), A handle is located at the back of the seat base. Pulling the handle upwardly allows the seat to release from its mount and be removed from the vehicle.

The driver's seat frame cannot be removed. The driver seat back is removable for access to the ECU, fuse box, and diagnostic port (Z10-4 , the left side passenger seat in the second row is removed). Pull out the grommet pins under the seat back forward and lift up to remove it (Follow the same procedure to remove all the seat backs). The driver and passenger seat bases can be removed separately by pulling the front end of the cushion to release the grommet pins and remove them.

## CONTROLS & FEATURES

### Tool Kit - (25)

A tool kit is located in the storage box in front of the passenger seat. Use for vehicle daily maintenance and service.

### Front Camera - (26- If equipped)

The front camera is located in the middle of the cross pipe at the top of the bumper. The front image function can be accessed through the menu of the Ridesync MMI.

### Rear Camera - (27)

The rear camera is located in the middle of the rear lower panel of the vehicle. The rear image function can be accessed through the menu of the Ridesync MMI. When the transmission is shifted to reverse gear, the Ridesync MMI automatically presents the rear camera image.

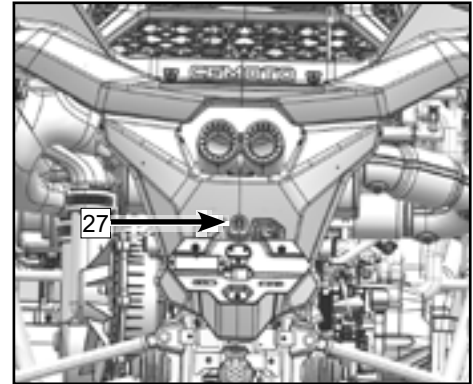

## CONTROLS & FEATURES

### Safety Belts

This vehicle is equipped with 3-point safety belts to help protect the driver and passenger(s) in the event of collisions, rollovers or tip-overs and to help keep occupants in the cab. Make sure the safety belt is firmly fastened before operation.

 **WARNING**

**Falling from a moving vehicle will lead to serious injury or death. Always fasten the safety belts before operating or driving the vehicle.**

Follow the below steps to fasten the safety belt:

- For the 3-point safety belt, pull the latch plate **1** down and pass it through the chest towards the buckle aside the seat. The safety belt should comfortably pass through the buttock and the diagonal of the chest. Make sure there is no distortion or twist in the safety belt.
- Insert latch plate **1** into the buckle **2** until there is click sound.
- Loosen a little of the safety belt and adjust fit as necessary, then allow it to retract automatically.
- Press the red button in the center of the safety belt buckle to release the latch plate.

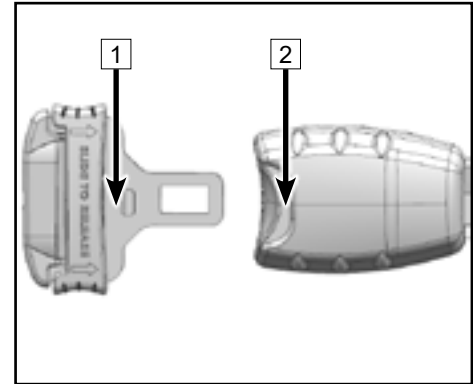

## CONTROLS & FEATURES

### CVT System

This vehicle has a Continuously Variable Transmission (CVT) system that utilizes a drive belt and clutch pulleys to automatically vary transmission drive ratios, allowing infinite variability between the highest and lowest vehicle speeds with no discrete steps or shifts.

The CVT system consists of CVT drive pulley [1], driven pulley [2] and drive belt [3].

The drive pulley [1] is mounted on the engine crankshaft [A]. The driven pulley is mounted on the input shaft of the transmission [B]. The drive belt [3] is a heavy duty V-belt that connects the drive and driven pulleys.

A CVT housing and cover encloses the clutches and belt assembly. The CVT components do not contain any user maintenance items. Contact your dealer for service.

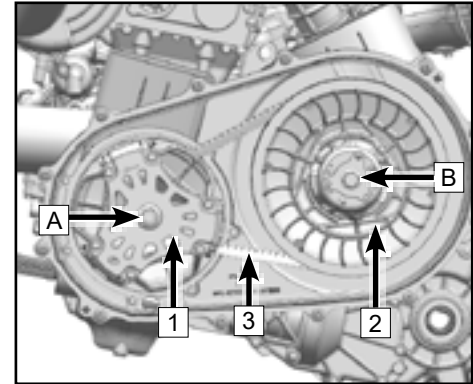

#### NOTE

To prevent belt damage, use low gear in heavy load situations or when operating continuously at less than 19 mph (30 km/h) for extended periods of time. If towing the vehicle becomes necessary, shift the transmission into neutral for better mobility and to prevent damage to the belt.

## CONTROLS & FEATURES

### What to do if water collects in the CVT housing

If the vehicle was submerged in water deep enough that water has entered the CVT housing, remove the drain bolt (1) at the bottom of the housing to drain the water from the case.

#### **⚠ CAUTION**

**If water drains from the CVT housing after removing the bolt, have your dealer inspect the vehicle, as water may have affected the CVT system and other engine parts.**

### Drying a Wet CVT System

If the CVT system was submerged and the drive belt is slipping, any remaining moisture inside the CVT housing after draining can be expelled by running the engine above 2500 RPM in Park or Neutral for 30~60 seconds, then test for proper CVT function in low gear. Repeat as necessary. If the CVT system continues to slip or have poor performance, contact your dealer.

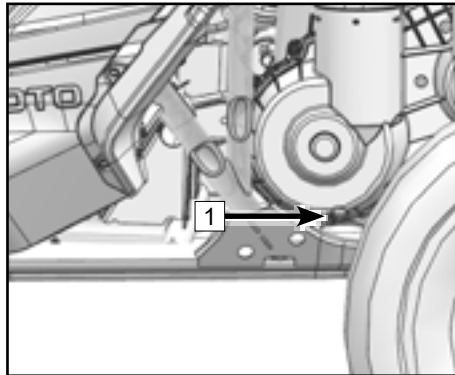

## CONTROLS & FEATURES

### How To Avoid CVT Drive Belt and Component Failure

CVT clutch and belt life can be dramatically extended by avoiding these common operating mistakes:

<b>Causes CVT damage:</b>	<b>How To Avoid CVT Failure:</b>
Attempting to load the vehicle onto a truck bed or tall trailer in high gear.	Shift transmission to low gear during loading of the vehicle to prevent belt burning.
Starting out on a steep incline in high gear.	When starting out on steep inclines, use low gear.
Constant driving in high gear at low RPM, at just above clutch engagement RPM, or at low speed (approximately 3 ~ 7mph [5 ~ 10 km/h]).	Low gear is highly recommended for cooler CVT operating temperatures and longer component life. Drive at a higher speed or use low gear more frequently.
Insufficient warm-up of CVT exposed to low ambient temperatures.	Warm the engine before driving, the CVT drive belt will become more flexible and prevent belt burning.
Towing / pushing at low RPM/low ground speed.	Use low gear only.
Utility use / plowing snow, dirt, etc.	Use low gear only.
Heavy vehicle load operating at low speed.	Use low gear only.

## CONTROLS & FEATURES

Causes CVT damage:	How To Avoid CVT Failure:
Stuck in mud or snow.	Shift the transmission to low gear, and carefully use fast, aggressive throttle application to engage CVT. <b>WARNING:</b> Excessive throttle may cause loss of control and vehicle overturn.
Climbing over large objects from a stopped position.	Shift the transmission to low gear, and carefully use fast, brief, aggressive throttle application to engage the CVT. <b>WARNING:</b> Excessive throttle may cause loss of control and vehicle overturn.
Belt slipping from water or snow ingestion into the CVT system.	Drain the water from the CVT housing and dry the CVT if possible, or contact your dealer.
Overheating of the CVT components causes malfunction.	Contact your dealer for inspection and repair of the CVT components.

### NOTE:

Low gear is the preferred transmission gear selection for the following situations:

- Constant driving at speeds lower than 19 mph (30 km/h).
- Driving on level ground, and the vehicle is carrying/towing heavy loads (higher than 584 lb. [265 kg]).
- Driving on rough or muddy ground, and the vehicle is carrying/towing heavy loads (higher than 430 lb. [195 kg]).

# CONTROLS & FEATURES

## Dashboard Indicators and Warnings

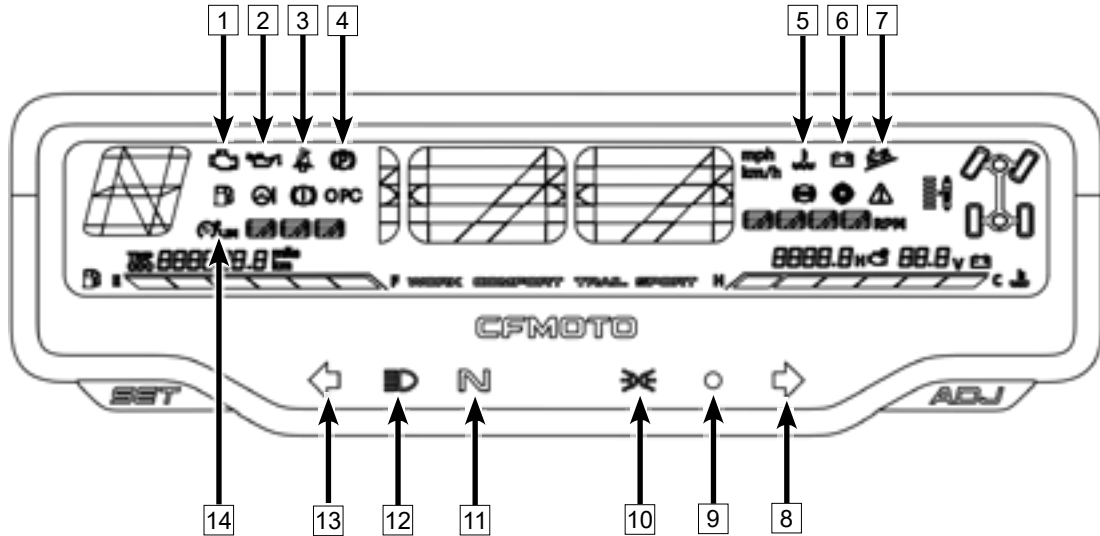

## CONTROLS & FEATURES

1	EFI Fault Indicator	6	Low Battery Warning Indicator	11	Neutral Indicator
2	Oil Pressure Indicator	7	DAC Indicator (Select Markets)	12	High Beam Indicator
3	Seat Belt Warning Indicator	8	RH Turning Light Indicator	13	LH Turning Light Indicator
4	Parking Brake Indicator	9	Key-less Indicator	14	Speed Limit Indicator
5	Coolant Temperature Warning Indicator	10	Position Light Indicator		

### 1. EFI Fault Indicator

This indicator displays when a fault occurs in the Electronic Fuel Injection system.

### 2. Oil Pressure Indicator

The oil pressure indicator illuminates when the oil pressure is low. Stop your vehicle safely at once if the indicator is on, and contact your dealer.

### 3. Seat Belt Warning Indicator

The indicator illuminates when the safety belt is not fastened. The indicator on the dashboard will be always on and the engine RPM is limited to 3300 RPM when the latch plate is not inserted into the buckle. The indicator and the speed limit function will be off when the latch plate is inserted into the buckle.

### 4. Parking Brake Indicator (If handbrake equipped)

When the driver pulls the handbrake to park, the indicator is on.

### 5. Coolant Temperature Warning Indicator

Both over-low and over-high coolant temperature conditions are abnormal. Idle the vehicle to warm the engine when it's too cold, and park the vehicle when it's too hot to prevent the coolant from boiling. Keep the coolant temperature in a normal range.

## CONTROLS & FEATURES

### **6. Low Battery Warning Indicator**

The indicator is on when the vehicle battery is low. Please charge the battery in time to avoid affecting the battery life and normal operation of the electrical system.

### **7. DAC (Downhill Assist Control) Indicator (Select Markets)**

Press the DAC button (see secondary controls for more details) to turn on the DAC function. The indicator is on.

When the rider decreases the speed in a proper range during downhill, the DAC function starts to work and controls the speed within a safe range.

### **8. RH Turning Light Indicator (Select Markets)**

This indicator illuminates when the turning switch turns to RH turn light position.

### **9. Key-less Indicator (If equipped)**

This indicator displays when the NFC key is not inserted.

### **10. Position Light Indicator**

This indicator illuminates when the position light turns on.

### **11. Neutral Indicator**

This indicator displays when the transmission is in neutral.

### **12. High Beam Indicator**

This indicator illuminates when the headlight switch turns to high beam position.

### **13. LH Turning Light Indicator (Select Markets)**

This indicator illuminates when the turning switch turns to LH turn light position.

### **14. Speed Limit Indicator (If ABS Equipped)**

The user can set the maximum speed of the vehicle by the button.

## CONTROLS & FEATURES

### Dashboard Indicators and Warnings

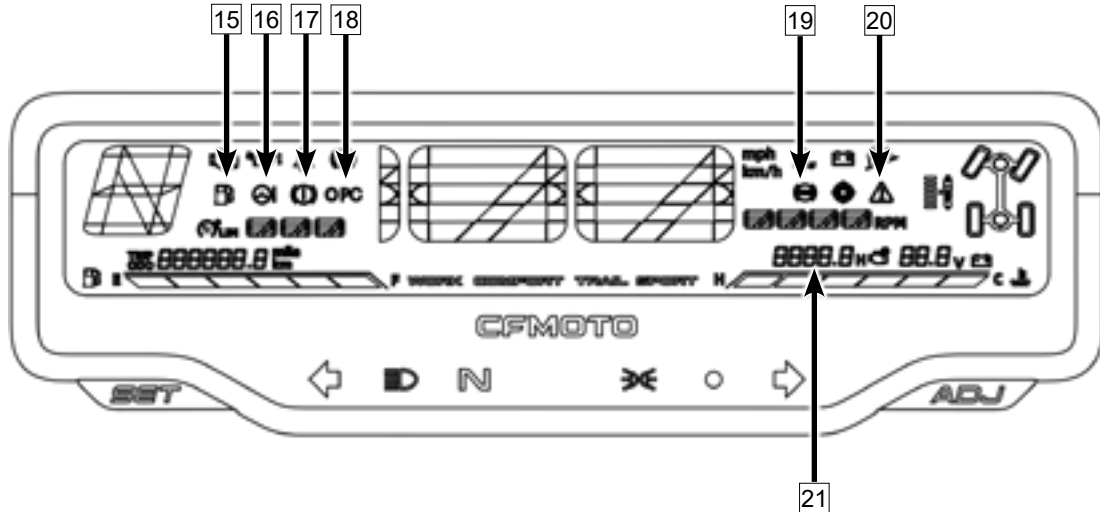

15	Fuel Gauge/Low Fuel Indicator	18	OPC Indicator	21	Engine Hours Indicator
16	EPS Indicator	19	ABS Fault Indicator		
17	Brake Fault Warning Indicator	20	Override Indicator Light		

## **CONTROLS & FEATURES**

### **15. Fuel Gauge/Low Fuel Indicator**

Display the fuel level in the fuel tank.

When the fuel level is close to the limit, please arrange remaining travel to add fuel as soon as possible. Insufficient fuel may cause damage to the fuel pump.

### **16. EPS Indicator**

This indicator will illuminate when a fault occurs in the Electronic Power Steering system. Please stop the vehicle and contact your dealer to eliminate the fault. Continuing to operate may lead to permanent damage to the EPS system and increase the turning force.

### **17. Brake Fault Warning Indicator**

This indicator will illuminate when the brake fluid level switch detects the fluid level is lower than the minimum level line.

## CONTROLS & FEATURES

### 18. OPC Indicator (If equipped)

When the driver leaves the seat without shifting to the parking position, this indicator will illuminate and an alarm sounds.

Ignition Lock	ON				OFF		
RPM	≤1800		>1800		/	/	/
Parking signal	Parking	No parking		Parking/No parking	No parking	No parking	Parking
Seat signal	Seat on/ Not seat on	Seat on	Not seat on	Seat on/ Not seat on	Not seat on	Seat on	Seat on/Not seat on
OPC	OPC	OPC	OPC	OPC	OPC	OPC	OPC
	OPC is silent	OPC is silent	OPC flashes and alarms	OPC is silent	OPC flashes and alarms for 5 minutes, then dashboard goes power off	OPC is silent, dashboard goes power off after 5 minutes	OPC is silent, dashboard goes power off after 5 minutes

## CONTROLS & FEATURES

### 19. ABS Fault Indicator (If equipped)

If there is any ABS fault, the ABS indicator will be on. Please contact an authorized CFMOTO dealer for repair.

### 20. Override Indicator Light (If equipped)

The engine is normally speed limited when operating in 4WD-LOCK. If conditions require more engine power:

Release the throttle and press the override button, the override indicator light will be on.

Press the button, then reapply the throttle.

Release the button to restore the speed limiting function.

<b>NOTE</b>
Override button cannot be used in 2WD/4WD modes.

 <b>WARNING</b>
<b>Do not press override button when the vehicle is in speed limiting mode and the throttle is open. Pressing the override button while the throttle is open may cause sudden acceleration, resulting in a loss of control, severe injury, or death. Always release the throttle before pressing the override button.</b>

### 21. Engine Hour Indicator

Display the current cumulative working time of the engine

## CONTROLS & FEATURES

Dashboard Navigation - Settings and Adjustments					
Item	Display	SET	ADJ	Operation	Result
Odometer	Total distance	Short press		Shift to trip	TRIP
Trip	Trip distance		Long press	Trip resets to zero	TRIP
Voltage	Voltage 'U'	Short press		Shift to backlit brightness	Brightness level
Dashboard brightness	Brightness level		Short press	Adjust brightness +1	Level 1-2-3-4-5
Home interface	Home interface		Short press	Adjust brightness +1	Home interface
	Km/Mile format interface		Short press	Toggles Km/Mile Format	Km/Mile format set
		Short press		Exit to home interface	Home interface
	Software version	Long press	Long press	Shift to software version	Home interface

## CONTROLS & FEATURES

### Ridesync MMI

#### **WARNING**

**For safety reasons, operating functions on the Ridesync MMI are only allowed when the vehicle is stopped and transmission in Park.**

Click the icon "" on the Ridesync MMI to enter the multimedia interface.

Click the icon "" on the Ridesync MMI to enter the Setting.

Click the icon "" on the Ridesync MMI to enter the application interface.



## CONTROLS & FEATURES

On the application center interface, users can inspect, adjust and set the following items:

1. Music
2. Navigation
3. Camera
4. Telephone
5. Apple CarPlay
6. Dashboard
7. Settings
8. Member Center
9. G-force
10. Fault Query
11. Controls
12. Tips

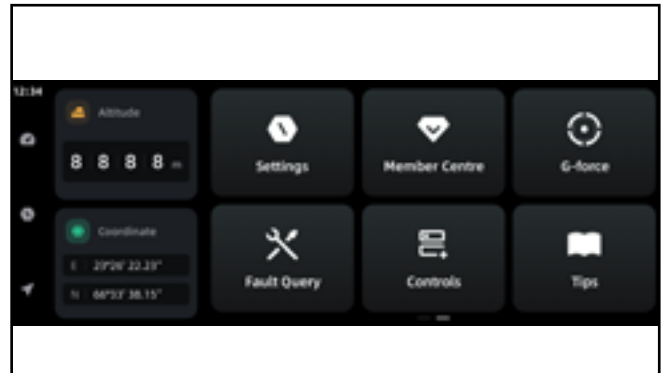
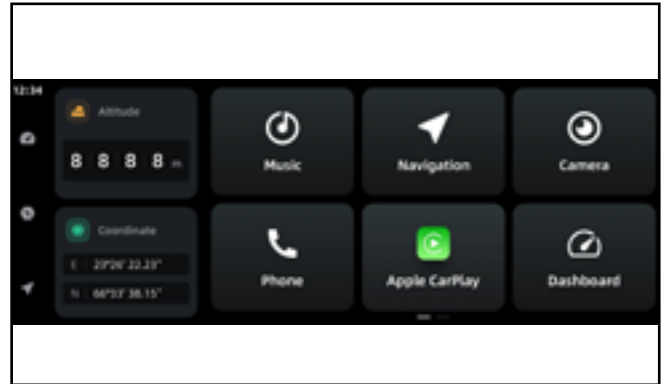

## CONTROLS & FEATURES

### Music - 1 (2-1)

On the music interface, the user can select their desired sound source (Bluetooth music or Radio).

**NOTE: Before playing music, ensure that the cellphone, Bluetooth, or USB equipment is connected to the vehicle system via Bluetooth.**

Turn on the cellphone music app.

Method 1:  - Click the icon to enter the multimedia interface.

Method 2:  - Click the icon to enter the music interface.

Select the sound source. For example, to select the Bluetooth music to play song:

: Click this icon or operate the function knob to switch to the prior song.

: Click this icon or operate the function knob to switch the next song.

: Click this icon or operate the function knob to play/pause the music.

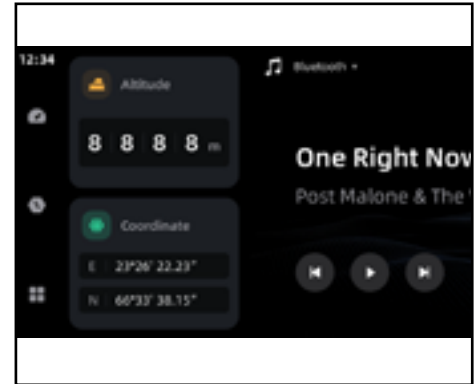

## Music - 1 (2-2)

## CONTROLS & FEATURES

On the multimedia interface, users can turn on the radio and listen to radio programs such as music, news, and entertainment.

Method 1:  - Click the icon to enter the multimedia interface.

Method 2:  - Enter the application center interface. Click the icon to enter the multimedia interface.

Click the drop-down menu to switch to radio for radio programs.

: Click the icon or operate the function knob to switch to prior station.

: Click the icon or operate the function knob to switch to next station.

: Click this icon or operate the function knob to play/pause the radio program.

: Click this icon to collect the station.

: Click this icon to automatically search for waveband.

: Click "FM/AM" to change waveband.

**NOTE: Connecting electronic devices that are not approved by CFMOTO, such as USB chargers, may interfere with the reception of radio signals.**

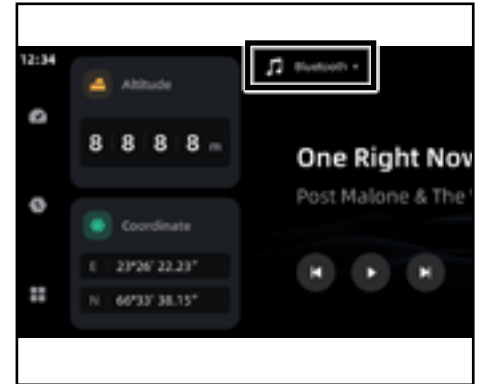

## CONTROLS & FEATURES

**NOTE:** The external environment (e.g. mountains, buildings, tunnels, underground parking lots, etc.) may affect signal reception, which is caused by the propagation of radio waves. It does not indicate a radio fault.

### Navigation - 2

Through the Ridesync MMI menu to project the navigation.

: Enter the application center interface. Click this icon to enter the navigation interface.

The following functions can be selected when on the navigation interface.

1	Search	2	Back to my location
3	OFF LINE mode/ON LINE mode	4	Zoom in
5	Zoom out	6	Compass
7	Map setting	8	Off-road function

### WARNING

**Navigation features only assist the driver. Always stay cautious, aware, and operate with a sense of responsibility. Follow all traffic rules and regulations while using the navigation information and controlling the vehicle.**

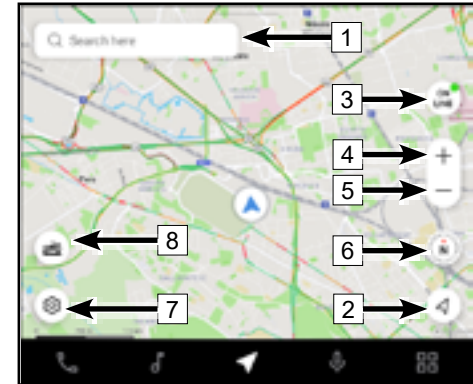

## CONTROLS & FEATURES

### Camera - 3

Through the Ridesync MMI menu to realize front and rear camera image function.



: Enter the application center interface. Click this icon to enter camera.



: Click the flipping page function to switch between front /rear camera imaging.

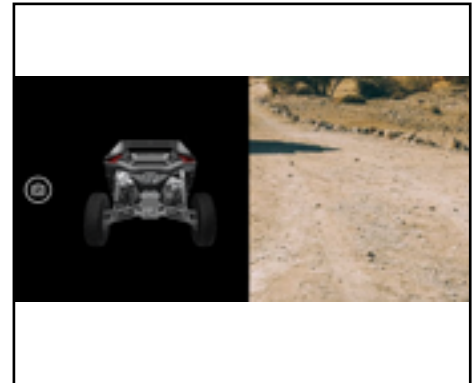

## CONTROLS & FEATURES

### Telephone - 4

On the telephone interface, the user can check contacts, recent calls, contact record, and dial the number.

**NOTE: Before using the telephone, the vehicle must be connected to a helmet with phone communication ability.**



: Enter the application center interface. Click this icon to enter the telephone interface.

Enter the telephone interface to check the contacts, contact record and recent calls.



### DANGER

**Do not use the telephone functions during riding.**

**During riding, Bluetooth headsets or in-car phone systems may distract attention and slow reaction.**

**Please park safely before answering an incoming call.**

## CONTROLS & FEATURES

### Apple CarPlay - 5

#### CarPlay Phone Connection



CarPlay phone connection can be accessed by wireless connection.

Connect the device as follows:

Make sure that the Bluetooth of the phone that needs to be connected is turned on.

Click this icon “” to enter the application center.

Click this icon “” to enter the setting.

Click this icon “”, click “connect the phone”, and click the icon “” to turn on the switch (This function is turned on by default when the vehicle is powered on each time, and you need to turn on this function manually if you turn it off manually), then the vehicle system will automatically search for the available Bluetooth ID

Click and connect the Bluetooth ID that needs to be connected.

Click to pair when the instrument screen and your phone pop up a pairing request.

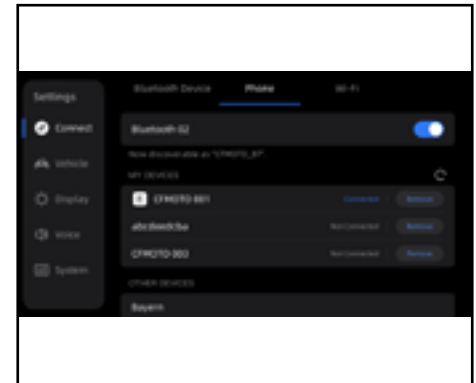
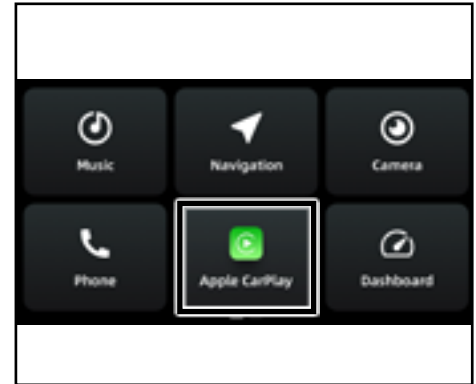

## CONTROLS & FEATURES

After pairing, the instrument screen will pop up “Enable Bluetooth” and “Enable Apple Carplay”, click “Enable Apple Carplay”.

Enter the Apple Carplay interface, and the icon “” will turn green after a successful connection.

### Disconnection

After the successful connection, click the “Exit” icon to disconnect and then return to the setting interface.

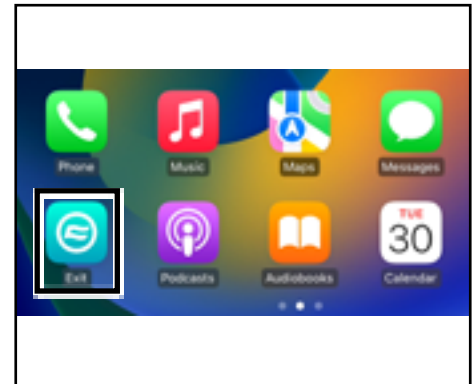
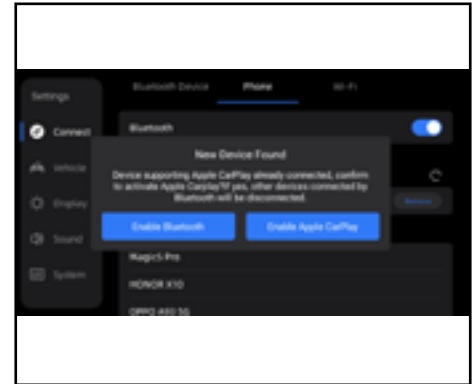



## CONTROLS & FEATURES

### Dashboard - 6

On the dashboard interface, the user can view the vehicle speed, drive mode and gear information, and edit the display interface.

Click the icon "  " to enter the applicator center.

Click the icon "  " to enter the dashboard.

The dashboard display interface can choose to display 1-6 contents. Click "  " in the upper right corner of the desired icon, and this function will be displayed on the dashboard screen. If you want to delete it, click "  " in the upper left corner of the function key on the left and right sides of the editing page to delete it.

In the display menu, the user can display or hide the following items:

- 6.1. Horsepower
- 6.2. Torque
- 6.3. Body posture
- 6.4. Altitude
- 6.5. G-force
- 6.6. Coordination
- 6.7. Direction
- 6.8. Water temperature
- 6.9. Oil
- 6.10. Battery voltage
- 6.11. Time

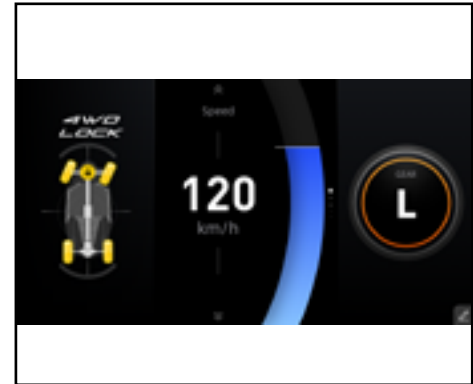

## CONTROLS & FEATURES

### Settings - 7

In the settings, riders can adjust and set the following contents:

- 7.1. Equipment Connection
- 7.2. Vehicle Setting
- 7.3. Brightness Control Adjustment
- 7.4. Volume Adjustment
- 7.5. System Setting

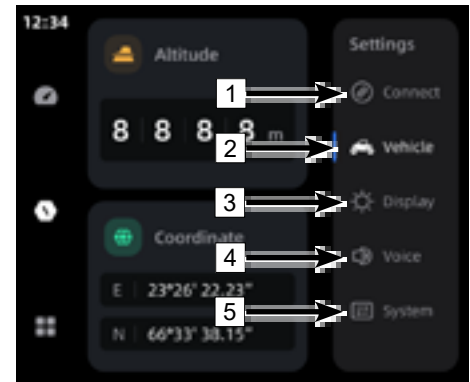
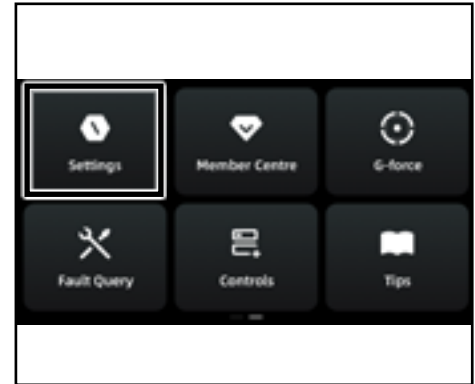

## CONTROLS & FEATURES

### Equipment Connection - 7.1

#### Bluetooth Equipment - 7.1.1

Navigation, telephone calls and music functions can be used after the Bluetooth equipment (e.g. Bluetooth earphones) is connected to the vehicle system via Bluetooth.

Follow these steps to connect the equipment:

Ensure that the Bluetooth is turned on before the connection.

Click the icon "☐☐" to enter the application center.

Click the icon "⬡" to enter the Setting.

Click the icon "Ⓜ", click the "Bluetooth Equipment", and click "🔵" turn on the switch. (This function is turned on by default when the vehicle is powered on each time, and you need to turn on this function manually if you turn it off manually). Click Bluetooth Equipment 1 or Bluetooth Equipment 2, the vehicle system will search for the available Bluetooth ID automatically. Click the needed Bluetooth ID to connect.

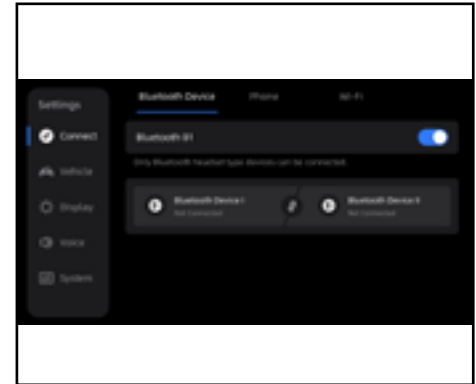

## CONTROLS & FEATURES

### Phone Connection - 7.1.2

Navigation, telephone calls and music functions can be used after the telephone is connected to the vehicle system via Bluetooth.

Follow these steps to connect the equipment:

Ensure that the Bluetooth is turned on before the connection.

Click the icon "☐" to enter the application center.

Click the icon "⚙️" to enter the Setting.

Click the icon "📶", click the "Phone Connection", and click the icon "🔵" to turn on the switch (This function is turned on

by default when the vehicle is powered on each time, and you need to turn on this function manually if you turn it off manually).

The vehicle system will search for available Bluetooth IDs automatically. Click the desired Bluetooth ID to connect.

The instrument screen and your phone will pop up a window to pair.

After the connection succeeds you will see "Connected" show up.

### Disconnection

If the equipment is connected, click the word "Connected", then the word will change to "Disconnecting". The word will change to "Disconnected" once the equipment is completely disconnected.

### Clear the equipment

In "Connection" or "Disconnection" status, click "Clear the equipment", the Bluetooth equipment will be disconnected and the Bluetooth ID will be removed.

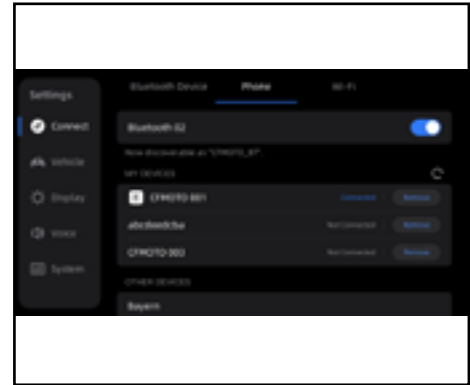

## CONTROLS & FEATURES

### Wi-Fi - 7.1.3

The vehicle system can be connected to the external Wi-Fi to ensure the upgrade works well.

Click the icon "☐" to enter the application center.

Click the icon "⬠" to enter the Setting.

Click the icon "⊙", click the "Wi-Fi", and click the icon "🔵" to turn on the switch (This function is turned on by fault when the vehicle is powered on each time, and you need to turn on this function manually if you turn it off manually). The vehicle system will search for the external Wi-Fi ID automatically.

Click the desired external Wi-Fi ID to connect.

After the Wi-Fi ID is connected, 'Connection' will appear.

### Disconnection

If the equipment is connected, click the word "Connected", then the word will change to "Disconnecting". The word will change to "Disconnected" once the Wi-Fi is completely disconnected.

### Delete

In "Connection" or "Disconnection" status, click "Delete". The Wi-Fi will be disconnected and the Wi-Fi ID will be removed.

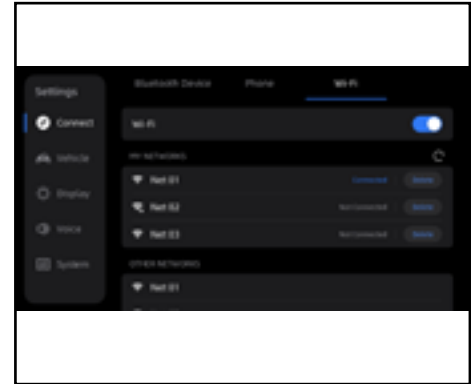

## CONTROLS & FEATURES

### Vehicle Setting - 7.2

In the system setting interface, the user can set and inspect the following items.

7.2.1 Drive Mode

7.2.2 EPS

7.2.3 Suspension

7.2.4 Drive Train

Click the icon "  " to enter the application center.

Click the icon "  " to enter the Setting.

Click the icon "  " to enter the Vehicle Setting interface.

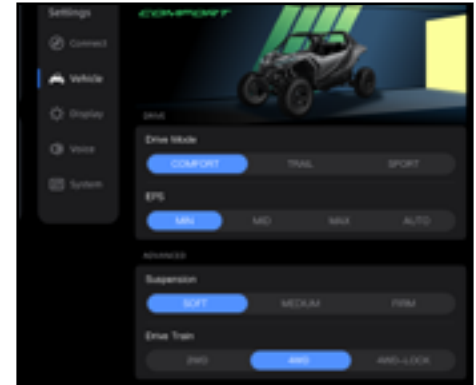

## CONTROLS & FEATURES

### Brightness Control Adjustment - 7.3

Manually adjust the brightness of the instrument, or turn on the automatic adjustment function (When the automatic adjustment is turned on, a photo-sensor adjusts the brightness of dashboard automatically according to the external environment light).

Click the icon "  " to enter the application center.

Click the icon "  " to enter the Setting.

Click the icon "  " to enter the brightness control adjustment interface.

Click the icon "  " to turn on or off the automatic adjustment function.

After turning off the automatic brightness adjustment, the brightness can be adjusted manually.

Press the brightness adjustment column to the right, the brightness is increased.

Press the brightness adjustment column to the left, the brightness is increased.

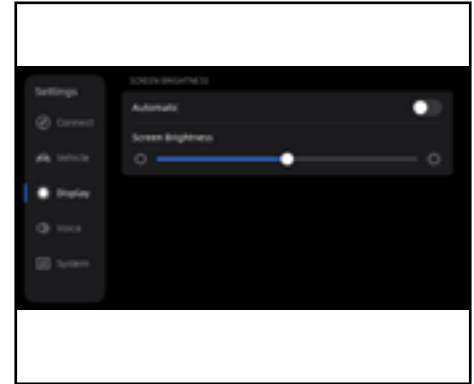

## CONTROLS & FEATURES

### Volume Adjustment - 7.4 (7.4-1)

In the volume settings, the user can adjust the following contents:

Media volume

Phone volume

VR (voice recognition) volume

Ringtone volume

Map volume

Click the icon "  " or operate the knob on the function switch to enter the application center.

Click the icon "  " or operate the knob on the function switch to enter the Setting.

Click the icon "  " to enter the volume adjustment interface.

Select the desired volume.

Press the volume adjustment column to the right, the volume will increased.

Press the volume adjustment column to the left, the volume will increased.

In some situations, the user can adjust the volume through the knob on the function switch (see knob operation table on the function switch for details).

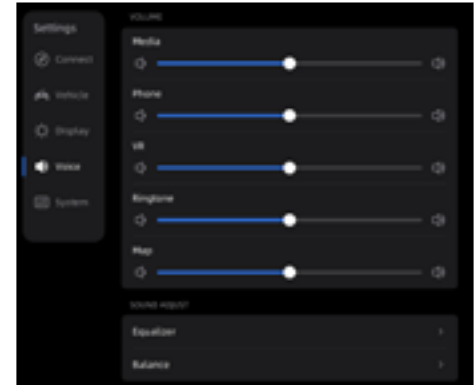

## CONTROLS & FEATURES

### Volume Adjustment - 7.4 (7.4-2)

In the prompt tone menu, the user can adjust the following contents:

Touch tone

Ringtone

Broadcast sound

Click the icon "" or operate the knob on the function switch to enter the application center.

Click the icon "" or operate the knob on the function switch to enter the Setting.

Click the icon "" to enter the volume adjustment interface.

Select the desired prompt tone, click it to enter.

Select the type of the prompt tone, click it to confirm.

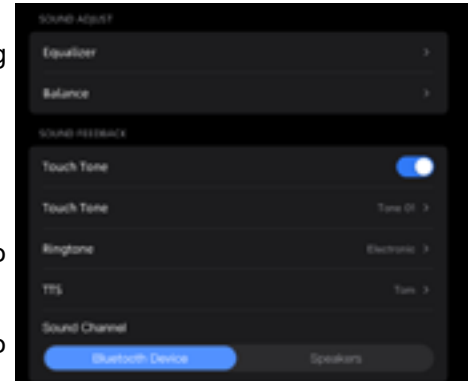

## CONTROLS & FEATURES

### System Setting - 7.5

In the system setting, the user can inspect and adjust the following contents:

7.5.1 Time setting

7.5.2 Language

7.5.3 Temperature unit

7.5.4 System information

7.5.5 Reset all

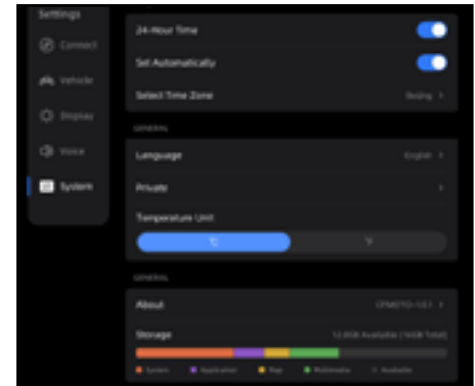

## CONTROLS & FEATURES

### 7.5.1 Time Setting

In the time setting menu, users can turn on/off the 24 hour time format and online time, and to select the time zone.

Click the icon "🗄️" to enter the application center.

Click the icon "⚙️" to enter the Setting.

Click the icon "⏮️" to enter the general setting interface.

Click the icon "🔘" to turn on/off the 24 hours time format.

Click the icon "🔘" to turn on/off the online time.

Select the time zone when the online time is turned on.

Click "Select the time zone" to enter the time zone interface.

Select your located "Region" and "Time Zone".



## CONTROLS & FEATURES

### 7.5.2 Language

Adjust the instrument's language to your preference.

Click the icon "☐" to enter the application center.

Click the icon "⬠" to enter the Setting.

Click the icon "⌂" to enter the general setting interface.

Click the "Language" to enter the language interface.

Select the desired language, and confirm your selection.

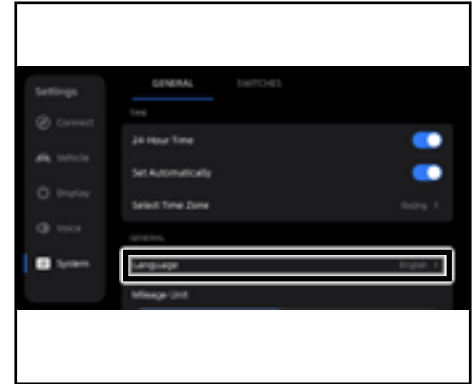

## CONTROLS & FEATURES

### 7.5.3 Temperature Unit

Change units of the temperature to suit your reading habits.

Click the icon "☐" to enter the application center.

Click the icon "⚙️" to enter Setting.

Click the icon "⏪" to enter the general setting interface.

Switch the unit format:

°C / °F

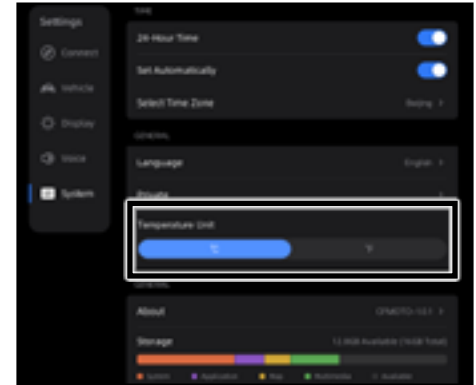

## CONTROLS & FEATURES

### 7.5.4 System Information

On the Information interface, the user can view the following information:

- CF OS version
- Hardware version
- MCU version
- Dashboard
- Serial No.
- Bluetooth address
- WLAN address
- P/N
- Storage

Click the icon "  " to enter the application center.

Click the icon "  " to enter the Setting.

Click the icon "  " to enter the general setting interface.

Click "About" to enter the About interface.

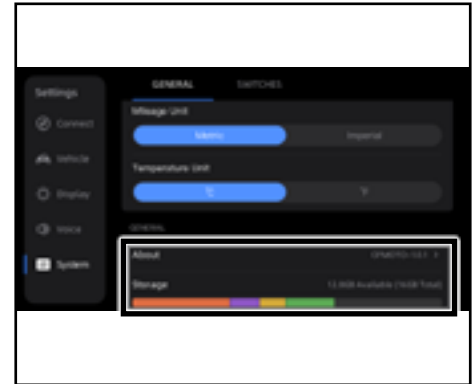

## CONTROLS & FEATURES

### 7.5.5 Reset All

To reset all instrument settings to factory defaults:

Click the icon "☐" to enter the application center.

Click the icon "⬡" to enter the Setting.

Click the icon "☰" to enter the general setting interface.

Click "Reset", the instrument screen will pop up a confirm window.

Click the "Confirm" to reset to the factory setting state.

**NOTE: This function does not reset ODO or related functions.**

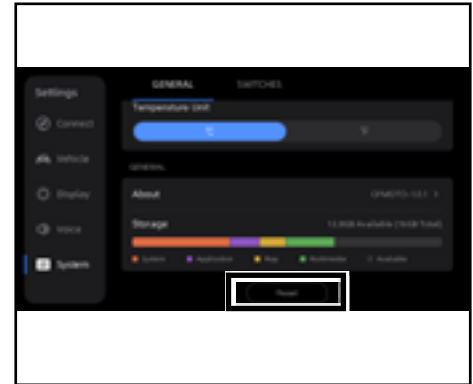

## CONTROLS & FEATURES

### Member Center - 8

The user can update the vehicle system in the member center interface.

When the vehicle system detects a new version, the system will pop up an active upgrade window reminder in the instrument. If it is inconvenient for users to upgrade, they can also enter the member center in their spare time to download and update the new version.

Follow these steps to upgrade the system:

Click the icon "  " to enter the application center.

Click the icon "  " to enter the member center.

Click the system to upgrade.

Download the system update file.

Click the update file, the system will be updated.

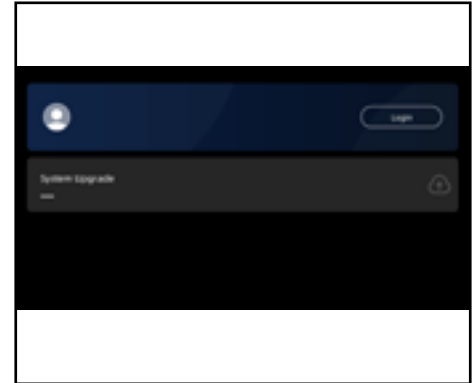

#### NOTE

Always park the vehicle safely, ensure that the power battery is fully charged, and that a stable network connection is available before upgrading the system. During the upgrade, the instrument will restart and present a black screen. This is normal. Please wait patiently.

## CONTROLS & FEATURES

### G-force - 9

Users can inspect vehicle attitude and switch the theme on the G-force interface.

Click the icon "🗄️" to enter the application center.

Click the icon "🎯" to enter the G-force.

Click the "vehicle attitude" to inspect the real-time vehicle attitude.

Click the "theme" to switch the theme.



## CONTROLS & FEATURES

### Fault Query - 10

On the Fault Query interface, users can view the fault or fault warning when the vehicle system detects any fault. If a fault occurs, please contact an authorized CFMOTO service center to diagnose and remove the fault as soon as possible.

Click the icon "  " to enter the application center.

Click the icon "  " to enter the fault center.

Inspect the current vehicle fault information.

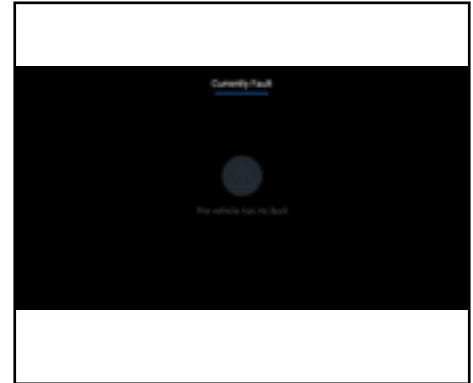

## CONTROLS & FEATURES

### Controls - 11

Click the icon "  " to enter the application center.

Click the icon "  " to enter the Controls.

Control the switch of the aftermarket component function on the vehicle.

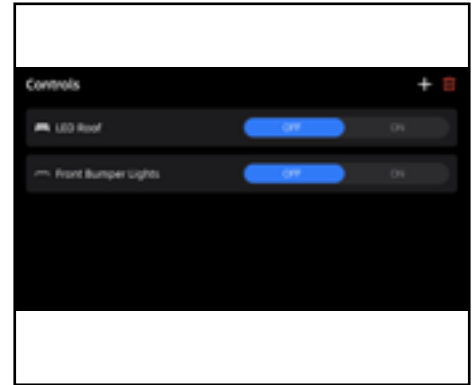

### Instruction - 12

Click the icon "  " to enter the application center.

Click the icon "  " to enter the Instruction.

Check the operation instruction for each function.



## CONTROLS & FEATURES

### Sidebar

Long press the sidebar on the Ridesync MMI to enter the set-up.

The show page can choose to display two features, click “+” on the top right corner of the desired icon, this function will be displayed on the instrument screen.

Click “” in the middle of the sidebar to switch the card function displayed up and down.

After the setting is completed, click "Done" in the top left corner to exit the setting interface.



## CONTROLS & FEATURES

### Hi Board

Turn on/off the auxiliary functions.

When this function is turned on, users can pull down the page to set related settings on the main screen.

### Voice Recognition (VR) <sup>1</sup>

Navigation, music, calls, radio, etc can be turned on and controlled using the voice recognition function.

**NOTE: A helmet with Bluetooth voice communication is required to be connected before using this function.**

#### How to activate / log out of VR:

Press the VR button on the steering wheel. The system will switch Bluetooth to voice recognition mode and an alert will sound (Ding-ding), indicating you can use the function.

When you say 'Cancel' to the voice assistant, you log out of voice recognition.

#### How to use the voice assist to navigate:

With voice control activated, speak "navigation", and the instrument will enter the navigation interface. You can say "which one" to select your destination. Or you can say "Next, go to page X" to flip over the page. During the navigation, speak "cancel", to cancel the navigation.



## OPERATING YOUR VEHICLE

### Voice Recognition (VR) Control Phrases

<b>Global</b>		
Cancel / Quit		
<b>Media</b>		
Play music	Pause music	Stop music
Previous	Next / Next Song/Next Track	Turn off music
<b>Radio</b>		
Open the Radio / Play Radio / Turn on the Radio / Close Radio / Stop Radio	Play FM / Play AM	Play FM 103.7 / Play AM 1000
Next station / Next radio station	Scan radio stations	Stop scanning
Add to favorites	Remove this station from favorites	
<b>Phone</b>		
Call Lisa / Make a call to Lisa / Contact Lisa	Call 13258 / Make a call to 0519853 / Dial 1234567	Call 911 / call...(emergency number)
Call Lisa's mobile number		
<b>Navigation</b>		
Zoom out	Zoom in	

## OPERATING YOUR VEHICLE

<b>System Settings</b>		
Volume up / Increase volume / Raise volume	Volume down / Decrease volume / Reduce volume / Lower volume	Mute
Unmute	Increase volume to max / Set volume to max / Increase navigation volume to max / Set max volume / Increase volume to maximum / Set volume to maximum	Decrease volume to minimum / Set volume to minimum / Reduce Volume to minimum
Increase screen brightness	Decrease screen brightness	Increase screen brightness to maximum
Decrease screen brightness to minimum	Set system / Navigation volume to 25	Set screen brightness to 5
<b>Open</b>		
Open settings / Open settings application	Open apple carplay / Open carplay	Open APP center
Open membership	Open vehicle information Display vehicle information Show vehicle information	

## OPERATING YOUR VEHICLE

### CFMOTO Accessory Bluetooth Communication

CFMOTO's specially-designed Bluetooth communication set for this vehicle (additional accessory) allows the user to connect and state a command without pressing the VR button for the following features:

<b>Feature</b>	<b>Voice Command</b>
Wake up the voice assistance	"Hi, CFMOTO/Hello CF"
Call incoming (not answered) to pick up the call	"Pick up the call"
Call ending (or 'do not answer') to hang up the call	"Hang up the call"
Increase the Bluetooth set volume	"Increase the volume"
Decrease the Bluetooth set volume	"Decrease the volume"
Play the last song	"Last song"
Play the next song	"Next song"
Pause the music	"Pause the music"
Play the music	"Play the music"

## OPERATING YOUR VEHICLE

### Operating Your Vehicle

#### Break-In Period

The break-in period for a new engine is very important. Careful treatment of a new engine at the beginning of ownership will result in more efficient performance and longer life. Perform the following procedures carefully:

1. Select an open area that allows room to familiarize yourself with vehicle operation and handling.
2. Place the vehicle on a level surface.
3. Fill the fuel tank with gasoline.
4. Check the engine oil level. Add the recommended oil if necessary to maintain the oil level at the middle upper line or equal to the upper line level.
5. Position yourself in the operating position on the vehicle, fasten the seatbelt, close the side doors, and start the engine. Allow the engine to idle for a short period before operating.
6. Press the foot brake, select the desired gear, and then release the foot brake.
7. Apply throttle. Drive slowly at first, varying throttle positions not more than  $\frac{1}{2}$  throttle for 10 hours or 150 miles / 250 km, then another 10 hours or 150 miles / 250 km of not more than  $\frac{3}{4}$  throttle (whichever interval arrives first). Do not operate at sustained idle or sustained wide open throttle.
8. Do not pull or carry any heavy loads during the break-in period.
9. Periodically check coolant level, controls, etc. along with items outlined in the maintenance chart.
10. At the end of the break-in period (20 hours or 300 miles / 500 km), change the oil and oil filter.

#### Brake System Break-in:

 **WARNING**

**Before the end of the break-in period, the brake system pads and discs are not at their optimal performance and require additional break-in. When operating on new brake pads and discs, do not follow other vehicles too closely or apply the brakes suddenly to avoid accidents.**

## OPERATING YOUR VEHICLE

### ⚠ CAUTION

**During the break-in period:**

- Do not operate at sustained full throttle. Damage to engine parts or decreased engine life may result if excessive wide open throttle is used during the first 20 hours or 300 miles/500 km of use.
- Do not run the engine with throttle over 1/2 open during the first 10 hours or 150 miles / 250 km of use (whichever interval arrives first).
- Do not run the engine with throttle over 3/4 open during the second 10 hours or 150 miles / 250 km (to 20 hours or 300 miles / 500 km) of use (whichever interval arrives first).
- Do not haul or tow heavy cargo.
- Use of any oil other than those recommended may cause serious engine damage. CFMOTO recommends the use of SAE 5W-40, SP or higher level API, full-synthetic oil for 4-stroke engines. Changing engine oil viscosity to SAE 0W-40 SP synthetic oil due to extreme cold environments, or to SAE 10W-50 SP synthetic oil due to extreme hot environments is acceptable. Reference the chart below for ambient temperature and viscosity choice.

							<b>10W-50</b>			
							<b>5W-40</b>			
							<b>0W-40</b>			
F	<b>-31</b>	<b>-22</b>	<b>-4</b>	<b>14</b>	<b>32</b>	<b>50</b>	<b>68</b>	<b>86</b>	<b>104</b>	<b>122</b>
C	<b>-35</b>	<b>-30</b>	<b>-20</b>	<b>-10</b>	<b>0</b>	<b>10</b>	<b>20</b>	<b>30</b>	<b>40</b>	<b>50</b>

## OPERATING YOUR VEHICLE

### Pre-Ride Inspection

Before each use of the vehicle, a best practice is to complete the pre-ride inspection checklist.

 <b>WARNING</b>
--

<b>If a proper inspection is not done before each use, severe damage to the vehicle, severe injury, or death could result. Always inspect the vehicle before each use to ensure it is in proper operating condition.</b>
--

### Throttle

Before starting the engine, check the throttle pedal to be sure it is operating smoothly. Make sure it returns to the idle position as soon as the pedal is released. Regulate the speed of the vehicle by varying the throttle position. Because the throttle pedal is an electrically operated mechanism controlled by an ECU, the vehicle will decelerate and the engine should return to idle speed any time your foot is removed from the throttle pedal.

## OPERATING YOUR VEHICLE

### Brakes

Before operating the vehicle, push down on the pedal to apply the front and rear brakes. When pressed, the lever or pedal should feel firm. A soft brake pedal would indicate a possible fluid leak or low master cylinder fluid level, which must be corrected before riding. Contact your dealer for proper diagnosis and repairs.

### Starting the Engine

 <b>WARNING</b>
--

<b>Never run an engine in an enclosed area. Engine exhaust contains poisonous carbon monoxide and can cause loss of consciousness, resulting in severe injury or death.</b>
---

### Starting a Cold Engine

1. Apply the foot brake.
2. Press the button "START/STOP" to start the engine.
3. Once the engine starts, allow the engine to warm up for a short period before operating the vehicle.

## OPERATING YOUR VEHICLE

### NOTE:

Do not activate the starting system for more than 10 seconds on each attempt. If the engine fails to start, release the start switch, pause a few seconds before the next attempt, then try starting again. Each attempt should be as short as possible to preserve battery power.

The engine can be started when the transmission is in Neutral or Park. If the neutral indicator on the dashboard does not come on when the gear selector is in the Neutral position, contact your dealer to inspect the indicator electrical circuit or adjust the gear shifting system.

### CAUTION

**Allow the engine to warm up for a short period before operating the vehicle. Operating the vehicle immediately after starting could cause engine damage.**

**Do not activate the starting system continuously. Failure to start the engine multiple times may cause the starting motor to burn out.**

## Shifting the Transmission

### CAUTION

**To avoid transmission damage, return the throttle to the closed position, stop the vehicle, and apply the foot brake before shifting.**

### NOTE:

Low gear is the preferred transmission gear selection when:

- Constant driving speeds are lower than 19 mph (30km/h)
- Driving on level road surfaces, and the vehicle is carrying/towing a heavy load.
- Driving on muddy or rough road surfaces, and the vehicle is carrying/towing a heavy load.

## OPERATING YOUR VEHICLE

### **Shifting Out of Park**

1. Verify the throttle is closed.
2. Apply the foot brake.
3. Shift to the desired gear by moving the gear selector along the shift guide.

### **Shifting: Neutral to High Gear**

1. Verify the throttle is closed and the vehicle is stopped completely.
2. Apply the foot brake.
3. Shift to 'H' by moving the gear selector along the shift guide.

### **Shifting: High Gear to Low Gear**

1. Verify the throttle is closed and the vehicle is stopped completely.
2. Apply the foot brake.
3. Shift to 'L' by moving the gear selector along the shift guide.

### **Shifting: Low Gear to High Gear**

1. Verify the throttle is closed and the vehicle is stopped completely.
2. Apply the foot brake.
3. Shift to 'H' by moving the gear selector along the shift guide.

## OPERATING YOUR VEHICLE

### Shifting: To Reverse Gear

1. Verify the throttle is closed and the vehicle is stopped completely.
2. Apply the foot brake.
3. Shift to 'R' by moving the gear selector along the shift guide.
4. Check behind you for people or obstacles, then release the rear brake pedal.
5. Apply the throttle lever gradually and continue to watch behind you while moving backward.

#### WARNING

**Before shifting into reverse, make sure there are no obstacles or people, and the area is safe behind you. When it is safe to proceed, go slowly.**

**Avoid excessive throttle operation in speed limit mode, as it may cause fuel to build in the exhaust, resulting in engine popping and/or engine damage.**

## OPERATING YOUR VEHICLE

### Shifting: To Park

1. Verify the throttle is closed and the vehicle is stopped completely.
2. Apply the foot brake.
3. Shift to 'P' by moving the gear selector along the shift guide. Shake the vehicle forward and backward to verify that parking is engaged.

### NOTE:

- The gear shift indicators should display corresponding to the actual gear position, if the indicator does not display, ask your dealer to inspect the vehicle electrical circuit or adjust the gear shifting system.
- Due to the synchronizing mechanisms in the engine, an indicator may not display until the vehicle starts moving.
- Do not use high gear for continuous slow speed travel or towing, as this can lead to excessive heating of the clutch system, which may damage components.

## **SAFE OPERATION - DRIVING SAFELY**

### **Safe Operation - Driving Safely**

#### **Responsibilities of the Operator**

As the operator of this vehicle, your common sense, judgment, and abilities are the only factors that will prevent injury to yourself, to others around you, and/or damage to the vehicle or environment.

#### **Recreational, Group, and Distance Riding**

One of the benefits of this vehicle is that it can take you off-road away from most communities. Stay away from areas designated for other types of off-road use unless it is specifically allowed. This includes snowmobile trails, equestrian trails, cross-country ski trails, mountain bike trails, etc. Join a local UTV or SSV club. A club can provide you with a map and advice, or inform you about areas where you can ride.

Always keep a safe distance from other riders ahead of you and behind you when riding in a group. Never operate carelessly or make unexpected maneuvers with other vehicles close by. Stay on designated trails and riding areas, and discourage others from operating in unauthorized locations.

#### **Avoiding Accidents, Rollovers and Tip-overs**

Side-by-side vehicles handle differently from other vehicles. Side-by-side vehicles are designed to handle off-road terrain (for example, the wheel base and track width, ground clearance, suspension, drive train, tires, etc.) and as a result, can overturn in situations where vehicles designed for use primarily on paved or smooth terrain may not.

#### **A rollover or other accident can occur quickly during abrupt maneuvers such as:**

- Sharp turns or hard acceleration.
- Deceleration when turning.
- When driving on hills or over obstacles.

## **SAFE OPERATION - DRIVING SAFELY**

Abrupt maneuvers or aggressive driving can cause rollovers or loss of control even in flat open areas. If the vehicle rolls over, any part of your body (such as arms, legs, or head) outside of the cockpit can be crushed and trapped by the cage or other parts of the vehicle. You can also be injured by impact with the ground, cab, or other objects.

### **To reduce the risk of rollovers:**

- Use care when turning.
- Adjust steering inputs accordingly to your speed and environment.
- Slow down before entering a turn.
- Avoid hard braking during a turn.
- Avoid sudden or hard acceleration when turning, even from a stop or low speed.
- Never attempt donuts, skids, slides, fishtails, jumps, or other stunts.
- If vehicle starts to skid or slide, steer in the direction of the skid or slide.
- Never slam the brakes and lock the wheels.
- This vehicle is built primarily for OFF-ROAD purposes. Riding on paved surfaces may seriously affect vehicle handling and control. If you must drive on paved surfaces for a short distance, reduce speed and avoid abrupt inputs to steering wheel, accelerator and brake pedals.

### **This vehicle can roll over sideways, or tip over forward or backwards on slopes or uneven terrain:**

- Avoid side hilling (driving along the slope rather than up or down a hill). When possible, drive straight up and down inclines rather than across them. If you must side hill, use extreme caution and avoid slippery surfaces, objects, or depressions. If you feel the vehicle start to rollover or slide sideways, steer downhill if possible.
- Avoid steep hills and follow procedures in this manual for climbing and descending hills.

## **SAFE OPERATION - DRIVING SAFELY**

- Sudden changes in terrain such as holes, depressions, banks, softer or harder ground or other irregularities may cause the vehicle to tip or become unstable. Observe the terrain ahead and slow down in areas of uneven terrain.

### **This vehicle will handle differently when carrying or pulling a load:**

- Reduce speed and follow instructions in this manual for carrying cargo or pulling a trailer.
- Avoid hills and rough terrain.
- Allow more distance to stop.

### **Be prepared in case of rollover:**

- Latch side doors and fasten seat belts to help you avoid sticking out arms or legs.
- Never grab the cage while riding. Hands can be crushed between the cage and the ground in a rollover. Keep hands on the steering wheel or handhold.
- Never try to stop a rollover using your arms or legs. If you think that the vehicle may tip or roll, the driver should keep both hands on the steering wheel and both feet firmly planted on the floor. The passenger should keep both hands on the handhold and both feet firmly planted on the floor.

### **Avoiding Collisions**

At higher speeds, there is an increased risk of losing control, particularly in challenging off-road conditions, and the risk of injury in a collision is greater. Never operate at excessive speeds. Always operate at a speed that is proper for the terrain, visibility, and operating conditions, and your experience. This vehicle does not have the same kind of protection for collisions as a car. For example, there are no air bags, the cab is not fully enclosed, and it is not designed for collisions with other vehicles. Therefore, it is particularly important to fasten seat belts, latch side doors, and wear proper riding gear.

## **SAFE OPERATION - DRIVING SAFELY**

### **Respect Your Environment**

Off-road recreation is a privilege. Maintain your privilege by respecting the environment and the rights of others to enjoy it:

- Chasing wildlife is illegal. Wildlife can die of exhaustion if chased by a motorized vehicle.
- Never purposely damage the terrain unless the operating area is designated for that type of activity.
- Observe the rule... "what you take in, carry out". Do not litter.

### **Practice Exercises**

Before you go out for a ride, it is very important to familiarize yourself with the handling of your vehicle by practicing in a controlled environment. Find a suitable area to practice and perform the following exercises. It should be at least 147 × 147 ft. (45 × 45 m), and free of obstacles like trees and large rocks.

Remember: Avoid higher speeds until you are thoroughly familiar with the operation of your vehicle.

### **Basic Driving Procedure**

**Familiarize yourself with engine start and gearshift operation. Follow these steps to practice:**

- Be aware of the obstacles around you, and confirm your route.
- When you sit in the driver's seat, fasten your seat belt, then place both hands on the steering and both feet firmly on the footboard.
- Practice 'start the engine'.
- Practice 'shifting the transmission' into low gear.
- Release the brake.
- Gently apply the throttle with your right foot. Slowly and steadily apply throttle. The speed of the vehicle is controlled by the amount of throttle applied. If you apply the throttle aggressively it will cause sudden acceleration.

## **SAFE OPERATION - DRIVING SAFELY**

- Start riding and practice throttle / brake operation.
- After you are familiar with throttle and brake operation, start learning the basic skills such as turning and reversing, etc.

### **NOTE:**

Do not use high gear for continuous slow speed travel or towing, as this can lead to excessive heating of the clutch system, which may damage components.

### **Turning Exercise**

Turning is one of the most frequent causes of accidents. It is easier for the vehicle to lose traction or rollover if you turn too sharply, or go too fast. Slow down when you approach a turn.

Practice turning:

- First, learn how to perform slight right turns at very low speeds. Release the throttle before turning and slowly reapply the throttle.
- Repeat the turning exercise, but this time maintain the throttle at the same level while turning.
- Finally, repeat the turning exercise while accelerating slowly.
- Practice exercises turning to the left.

Note how your vehicle reacts in these different exercises. CFMOTO recommends releasing the throttle before entering a turn to help initiate directional change. You will feel the lateral force increasing with the speed and with your steering input. The lateral force should be maintained as low as possible to make sure it does not cause the vehicle to roll over.

## SAFE OPERATION - DRIVING SAFELY

### U-turn Exercise

Practice doing U turns:

- Accelerate slowly and while remaining at low speed, gradually turn the steering wheel to the right until you have completed the U-turn.
- Repeat U-turn exercise with different steering inputs and always at a very low speed.
- Repeat U turn exercise to the left.

As mentioned before in this manual, do not ride on paved surfaces. The vehicle behavior will not be the same, increasing the risk of rollover.

### Braking Exercise

Practice braking to get familiar with the brake response:

- Practice braking at low speed first, then increase the speed.
- Practice braking in straight line at different speeds and different braking forces.
- Practice emergency braking. Optimal braking is obtained in straight line, with high force applied, without locking the wheels.

Remember, braking distance depends on vehicle speed, load and the type of surface. Also, the tires and brakes conditions play a major role.

### Reverse Exercise

Practice using the reverse:

- Place 1 cone marker on both sides of the vehicle beside each rear wheel.
- Move the vehicle forward until you can see the cone markers behind you, then stop the vehicle. Acknowledge the distance required to see obstacles behind you.
- Learn how the vehicle handles in reverse and reacts with steering inputs.
- Always perform this reverse exercise at slow speeds.

## SAFE OPERATION - DRIVING SAFELY

### Operating Your Vehicle

#### Off-Road Operation

The very nature of off-road operation is dangerous. Any terrain which has not been specially prepared to carry vehicles presents an inherent danger where terrain substance, shape, and steepness are unpredictable. The terrain itself presents a continual element of danger, which must be knowingly accepted by anyone venturing over it.

An operator who takes a vehicle off-road should always exercise the utmost care in selecting the safest path and keeping close watch on the terrain ahead. This vehicle should never be operated by anyone who is not completely familiar with the driving instructions applicable to the vehicle, nor should it be operated on steep or treacherous terrain.

#### General Driving Tips

Care, caution, experience and driving skill are the best precautions against the hazards of vehicle operation. Whenever there is the slightest doubt that the vehicle can safely negotiate an obstacle or a particular piece of terrain, always choose an alternate route. In off-road operation, power and traction, not speed, are important. Never drive faster than visibility and your ability to select a safe route permit. Never operate the vehicle if the controls do not function normally. See your dealer.

#### Operating in Reverse

When operating in reverse, check that the path behind the vehicle is free of people or obstacles. Pay attention to blind spots. When it is safe to proceed in reverse, go slowly and avoid sharp turns.



**Steering inputs in reverse operation increase the risk of rollover.**

## SAFE OPERATION - DRIVING SAFELY

### WARNING

**When driving downhill in reverse, gravity can increase the vehicle speed above the set limited reverse speed. Failure to use caution when operating in reverse can result in serious injury or death.**

#### **NOTE:**

This vehicle is equipped with a reverse speed limiter function. In reverse operation, the engine RPM is limited, thus limiting the vehicle reverse speed. Do not operate at wide open throttle. Open the throttle just enough to maintain a desired speed.

#### **Crossing Paved Roads**

If you have to cross a paved road, ensure to have complete visibility on both sides for incoming traffic and decide on exit point on other side of road. Drive in a straight line toward that point. Do not make sharp direction changes or abrupt accelerations as it may result in a rollover situation. Do not travel on sidewalks or bicycle trails, as they are designated specifically for those uses.

#### **Riding on Paved Surfaces**

Avoid paved surfaces. This vehicle is not designed to operate on paved surfaces and is more likely to roll over. If you must drive on pavement, turn gradually, go slowly, and avoid abrupt acceleration and braking.

#### **Shallow Water Crossing**

Water can be a unique hazard. If it is too deep the vehicle may “float” and topple. Check the water depth and current before you attempt to cross any water. Water depth should not exceed the bottom of the floorboard to safely cross the obstacle.

Beware of slippery surfaces such as rocks, grass, logs, etc., both in the water and on its banks. A loss of traction may occur. Do not attempt to enter the water at high speed. Water will affect the braking ability of your vehicle. Make sure you dry the brakes by applying them several times while driving slowly after the vehicle leaves the water.

## **SAFE OPERATION - DRIVING SAFELY**

### **What to Do If Vehicle is Submerged**

If the vehicle becomes immersed, it will be necessary to have it transported to your dealer as soon as possible. Do not attempt to re-start the engine, as water may have been ingested into the cylinders, which can cause internal damage.

### **Riding in Mud, Ice or Snow**

When performing a pre-ride inspection, pay special attention to locations on the vehicle where mud, ice and/or snow accumulations may obstruct visibility of the tail lamps, clog ventilation openings, block the radiator and fan, and interfere with the movement of controls. Before starting with your vehicle, check the steering, throttle and brake pedals for interference-free operation.

Whenever this vehicle is driven on a snow or ice covered path, the tire grip is generally reduced, causing the vehicle to react differently to control inputs from the operator.

### **Riding on Sand**

Sand and riding on sand dunes is a unique experience, but there are some basic precautions that should be observed. Wet, deep, or fine sand may create a loss of traction and cause the vehicle to slide, drop off or become “bogged” down. If this occurs, look for a firmer base. Again, the best advice is to slow down and be watchful of the conditions.

When riding on sand dunes, it is advisable to equip the vehicle with an antenna-type safety flag. This will help make your location more visible to others over the next sand dune. Proceed carefully should you see another safety flag ahead.

## **SAFE OPERATION - DRIVING SAFELY**

### **Riding on Gravel, Loose Stones, or Other Slippery Surfaces**

Riding on gravel or loose stones is very similar to riding on ice. They affect the steering of vehicle, possibly causing it to slide and tip over especially at high speeds. In addition, braking distance may be affected. Remember that “gunning” the throttle or sliding may cause loose stones to be ejected rearwards which could hit other people.

### **Crossing Obstacles**

Obstacles on the trail should be traversed with caution. This includes rocks, fallen trees, and depressions. You should avoid them whenever possible. Remember that some obstacles are too large or dangerous to cross and should be avoided. As a guideline, never attempt to cross an obstacle higher than the ground clearance of the vehicle. Small rocks or small fallen trees may be safely crossed. Approach obstacles at low speed and to as much a right angle as possible. Adjust speed without losing momentum and do not accelerate abruptly. The passenger must grasp handhold firmly and brace feet on the floor.

### **Hill Driving Conditions**

When driving on hills or slopes, two things are highly important: be prepared for slippery surfaces or terrain variations, obstacles, and brace yourself properly inside vehicle. If you climb or descend a hill that is too slippery or has too loose a surface, you can lose control. If you go over the top of a hill at high speed, you may not have time to prepare and react to conditions on the other side.

Avoid parking on a steep slope or incline. Placing the transmission in Park on a steep slope or incline places pressure on the parking gear, which can cause difficult shifting out of Park. If you must park on a steep slope or incline, apply the hand brake (If equipped) and block the wheels on the downhill side using rocks or other suitable material.

## **SAFE OPERATION - DRIVING SAFELY**

### **Uphill Driving**

Use low gear (L) for uphill driving. Due to its configuration, this vehicle has very good traction even while climbing, so much so that tip-over is possible before traction is lost. For example, it is common to encounter terrain situations where the top of the hill has eroded to a point that the hill peak rises very sharply. This vehicle is not designed to negotiate such a condition. Take an alternate route.

If you feel that the slope is getting too steep to climb, apply the brakes to immobilize the vehicle. Shift the transmission to reverse (R) and back straight down the hill while lightly applying the brakes to remain at low speed. Do not attempt to turn around. Never coast downhill while the vehicle is in neutral. Do not perform hard braking, as it increases the risk of tip-over.

### **Downhill Driving**

This vehicle can climb steeper slopes than it can descend safely. Therefore, it is essential to assure that a safe route exists to descend a slope before you climb it. Decelerating while negotiating a slippery downhill slope could “toboggan” the vehicle, causing it to slide. Maintain steady speed and/or accelerate slightly to regain control. Never slam the brakes and lock the wheels.

## SAFE OPERATION - DRIVING SAFELY

### Hauling and Towing Loads

Your vehicle can help you perform a number of different light tasks ranging from snow removal, to pulling wood, or carrying cargo. This can change the vehicle handling. To prevent possible injury, follow the instructions and warnings in this manual and on the vehicle.

Always respect the load limits of the vehicle. Overloading the vehicle can over-stress the components and cause failure.

### Carrying Loads

The load limit of the vehicle including the weight of operator, passenger, cargo, accessories and trailer towing hitch weight:

Z10 : 650.3 lb. (295 kg)

Z10-4 : 881.8 lb. (400 kg)

Following is an example of suitable total vehicle load distribution:

EXAMPLE OF SUITABLE VEHICLE TOTAL LOADS				
Models	Operator and Passenger(s)	1) Cargo Box Load 2) Towing Hitch Weight	Accessories Storage	Total Vehicle Load
Z10	352.7 lb. (160 kg)	1) 198.4 lb. (90 kg) 2) 88.2 lb. (40 kg)	99.2 lb. (45 kg)	650.3 lb. (295 kg)
Z10-4	705.4 lb. (320 kg)	1) 154.3 lb. (70 kg) 2) 88.2 lb. (40 kg)	22 lb. (10 kg)	882 lb. (400 kg)

### WARNING

Driving on level ground with total payload greater than 584 lb. (265kg), use low gear and the vehicle speed should be lower than 19 mph (30 km/h).

Driving on rough or muddy ground with total payload greater than 430 lb. (195 kg), use low gear and the vehicle speed should be lower than 19 mph (30 km/h).

## **SAFE OPERATION - DRIVING SAFELY**

### **Vehicle Settings When Carrying Loads**

If the total load approaches 650.3 lb. (295 kg - Z10), 882 lb. (400 kg - Z10-4 ), including weight of operator, passenger, cargo, accessories, and trailer towing hitch weight:

- Inflate the tires to maximum pressure.
- Readjust the suspension coil spring pre-load accordingly.
- Operate with the transmission in L (low gear) when carrying heavy loads in the cargo box and/or pulling a trailer (the vehicle speed should be lower than or equal to 9.3 mph [15 km/h]).

### **Load Distribution**

Your vehicle has been designed to carry or tow a certain amount of load. Always:

- Read and understand the load distribution warnings listed on the warning labels.
- Never exceed the specified weights.
- Cargo weight should be mounted as low as possible.
- When operating over rough or hilly terrain with loads or towing, reduce speed and cargo to maintain stable driving conditions.

### **Pulling or Towing**

Your vehicle is equipped with a hitch receiver and winch (if installed) for towing or pulling.

#### **Pulling a Load**

- Never pull a load by attaching it to the cage. This can cause the vehicle to tip over. Use only the trailer hitch or winch (if installed) to pull a load.
- When pulling loads with a chain or cable, ensure that there is no slack before starting and maintain tension while pulling.

## SAFE OPERATION - DRIVING SAFELY

### WARNING

**Slack can cause a chain or cable to break and snap back, possibly causing injury.**

- When pulling a load, respect the maximum hauling capacity.
- If pulling another vehicle, be sure that someone is controlling the pulled vehicle. They must brake and steer to prevent the vehicle from going out of control.
- Reduce your speed when pulling a load and turn gradually to avoid chains, straps, ropes or cables from catching on the rear wheels. Avoid hills and rough terrain. Never attempt steep hills. Allow more distance for braking, especially on inclined surfaces. Be careful not to skid or slide.
- Before pulling loads with a winch (if installed), refer to the winch section in this owner's manual.

### **Towing a Load**

If a trailer is used behind the vehicle, make sure that its hitch is compatible with the one on the vehicle. Make sure the trailer is horizontal with the vehicle. Use safety chains or cables that keep the trailer secured to the vehicle in the event of a hitch failure.

Improperly loading a trailer may cause loss of control. Respect the recommended maximum hauling capacity and maximum tongue load. Make sure there is at least some weight on the tongue. Follow these guidelines for hauling and towing of cargo:

### WARNING

**Overloading the vehicle, carrying or towing cargo improperly, can alter the vehicle handling and may cause loss of control or braking instability.**

## **SAFE OPERATION - DRIVING SAFELY**

- Always use low gear while towing to avoid clutch wear and belt issues.
- Reduce speed when hauling or towing loads.
- Never exceed the stated load capacity for this vehicle.
- All loads must be secured before operation. Unsecured loads may shift and create unstable operating conditions, which could result in loss of control of the vehicle.
- When operating over rough or hilly terrain, reduce speed and cargo to maintain stable driving conditions.
- Use extreme caution when applying brakes with a loaded vehicle. Avoid terrain or situations that may require backing downhill.
- Load weight distribution should be as low as possible. Carrying a high load raises the center of gravity and creates an unstable operating condition. Reduce load weight when the cargo center of gravity is high.
- When handling off-centered loads that cannot be centered, secure the load and operate with extra caution.
- When operating with loads extending beyond the cargo area, stability and maneuverability may be adversely affected, causing the machine to overturn.
- Towing a load while carrying cargo may cause an imbalanced condition that increases the possibility of vehicle overturn. Balance loads proportionally, but do not exceed the stated load capacity.
- Always attach to the tow using the hitch point and hardware specifically made for towing. Never exceed the recommended towing hitch weight.
- Using chains, straps, rope or other materials to tow objects is not recommended, as these items could get caught in the rear wheels, resulting in vehicle damage or personal injury.

## SAFE OPERATION - DRIVING SAFELY

- While towing, the vehicle should never exceed 10 mph (16 km/h) towing a load on a level surface. Vehicle speed should never exceed 5 mph (8 km/h) when towing loads in rough terrain, while cornering, or while ascending or descending a hill.
- When stopped or parked, block the vehicle and trailer wheels from possible movement.
- Use caution when disconnecting a loaded trailer; it or its load may topple on you or others.

<b>MAXIMUM HAULING CAPACITY</b>			
<b>Type of Attachment</b>	<b>Trailer Load Allowed</b>	<b>Trailer Hitch Weight Allowed</b>	<b>Note</b>
Hitch ball support	882 lb. (400 kg)	88.2 lb. (40 kg)	Includes trailer and trailer load

**When the trailer load approaches 881.8 lb. (400 kg) and the vehicle is operated on a flat surface, to ensure safety and prevent vehicle damage, the following measures should be taken:**

- **There is one operator and no other passengers in the vehicle.**
- **Switch to 4WD.**
- **Reduce the speed to under 9 mph (15 km/h).**
- **Use low gear to increase traction and stability.**

## SAFE OPERATION - DRIVING SAFELY

### Winch Operation

**(Select Markets)** Your vehicle may be equipped with a winch that can pull certain capacities and types of loads. It is useful for vehicle self-recovery when stuck, assisting another vehicle in recovery, moving fallen trees, removing brush, etc.

Consider practicing the operation and use of your winch before you actually need to use it.

The safety warnings, operating precautions and instructions in this section apply if your vehicle came equipped with a winch, or if you choose to install an accessory winch on your vehicle:

### Winch Safety Warnings

These safety warnings apply if your vehicle is equipped with a winch, or if you choose to install an accessory winch on your vehicle:

- Read and understand all sections of this manual.
- Improper winch use or failure to correctly follow the winch guidelines, instructions, and warnings in this manual can result in SEVERE INJURY or DEATH.
- Improper or lack of winch maintenance and service could lead to SEVERE INJURY or DEATH.
- Always keep body, hair, clothing, and jewelry clear of the winch cable, fairlead, and hook during winch operation.
- Always keep the area around the vehicle, winch, winch cable and load clear of people, pets, and distractions during winch operation.
- Always wear eye protection and heavy gloves during winch operation.
- Never use alcohol or drugs before or while operating the winch.
- Never allow children under 16 years of age to operate the winch.
- Never attempt to “jerk” a load attached to the winch by moving the vehicle.
- Never winch up or down, or to the sides at sharp angles. This can destabilize the winching vehicle and possibly cause it to move without warning.

## **SAFE OPERATION - DRIVING SAFELY**

- Never attempt to winch loads that weigh more than the winch capacity rating.
- Never touch, push, pull, or straddle the cable while winching a load.
- Never let the winch cable run through your hands, even if wearing heavy gloves.
- Never release the drum on the winch when the winch cable is under load.
- Never use the winch for lifting or transporting people.
- Never use the winch to hoist or suspend a vertical load.
- Never retract the hook fully into the winch. This can cause damage to system components.
- Never operate the winch or the vehicle if they are in need of repair or service.
- Always turn the ignition switch OFF and unplug the remote control (if equipped) to prevent inadvertent activation or unauthorized use when the vehicle or winch are not being used.

### **Winch Operating Precautions**

These operating precautions should always be followed if your vehicle is equipped with a winch, or if you choose to install an accessory winch on your vehicle:

- Always inspect your winch and winch cable before each use.
- Always use the provided hook strap when pulling cable out or guiding cable in. Never grab the hook.
- Always align the load directly in front of the vehicle and winch as much as possible. Avoid winching with the cable at a sharp angle to the winching vehicle's centerline whenever possible.
- If winching at an angle is unavoidable, follow these precautions while operating:
  - A. Look at the winch drum occasionally. Never let the winch cable "stack" or accumulate at one end of the drum. Too much cable at one end of the drum can damage the winch and cable.
  - B. If cable stacking occurs, stop winching. Follow the 'Winch Cable Spooling Guidelines' section in this manual to redistribute the cable evenly before continuing.

## SAFE OPERATION - DRIVING SAFELY

- Always apply the vehicle's park brake and/or park mechanism to hold the vehicle in place during winching. Use wheel chocks when necessary.
- Always maintain at least five full turns of cable wrapped around the winch drum at all times. The friction provided by the wrapped cable allows the drum to pull on the winch cable and move the load.
- Never grease or oil the winch cable. This will cause the winch cable to collect debris that will shorten the life of the cable.
- The winch motor and relay connector may become hot during continuous use. When winching for more than 45 seconds, or if the winch stalls during operation, stop and allow the winch components to cool for a minimum of 10 minutes before using it again.
- Never operate the winch without running the engine. The engine's charging system helps keep the battery maintained. Battery reserve capacity can be quickly exhausted by heavy winch use, rendering the starting system inoperable.
- Always operate with concern for the environment. Do not purposely damage trees, etc.

### Basic Winch Operation

Follow these operating instructions if your vehicle is equipped with a winch, or if you choose to install an accessory winch on your vehicle. Read ***Winch Safety Warnings and Winch Operating Precautions*** on the preceding pages before using your winch.

BEFORE YOU BEGIN - Realize that each winching situation is unique:

- Take your time to think through the winch operation you are about to perform.
- Proceed slowly and deliberately.
- Never hurry or rush during winching.
- Always pay attention to your surroundings.
- Be prepared to change your winching strategy if it is not working.
- Remember that although your winch is very powerful, there are simply some situations that you and the winch will not be able to deal with. Do not be afraid to ask others for help when necessary.

## SAFE OPERATION - DRIVING SAFELY

1. Always inspect the vehicle, winch, cable and controls for signs of damage or parts in need of repair before each use. Pay particular attention to the first 3 feet (1 meter) of winch cable if the winch is used (or has been used) for lifting a plow. Promptly replace any worn or damaged cable.
2. Apply the vehicle's park brake and/or park mechanism to hold the vehicle in place during winching. Use wheel chocks when necessary.
3. Release the winch drum and pull out the required length of cable. Always use the hook strap to handle the hook. Never remove the hook strap from the hook.

### CAUTION

**Always maintain a minimum of five (5) full turns of cable around the winch drum at all times. The friction provided by wrapping cable allows the drum to pull on the cable and move the load.**

4. Attach the hook onto the load, or use a tow strap or chain to secure the load to the winch hook. Never hook the winch cable back onto itself. This can damage the winch cable and result in cable failure.

### WARNING

**Never use a 'recovery strap' for winching. Recovery straps are designed to stretch and could release excessive energy that can result in SEVERE INJURY or DEATH if the strap or winch cable breaks. Use only undamaged tow straps or chains that do not stretch.**

5. Re-engage the winch drum.

## **SAFE OPERATION - DRIVING SAFELY**

6. Slowly winch in slack of the winch cable until it is gone, then stop and follow the instructions for 'winch damping' to ensure safe operation:
  - A. Place a damper on the mid-point of winch cable length to absorb energy that could be released by a winch cable failure. A damper can be a heavy jacket, tarp, or other soft, dense object. A damper can absorb much of the energy released if the cable breaks during winching. Even a tree limb can help as a damper if no other items are available to you.
  - B. Lay the damper on top of the mid-point of the winch cable length.
  - C. On a long pull, it may be necessary to stop winching so the damper can be repositioned to a new mid-point. Always release the tension on the winch cable before repositioning the damper.
  - D. Avoid being directly in line with the winch cable whenever possible. Also, never permit others to stand near or in line with the winch cable during winch operation.
7. Stop winching as soon as the job is completed or the load can be moved without the help of the winch.
8. Detach the winch hook, then rewind the cable evenly back onto the drum following the instructions in this manual.

### **Vehicle Recovery Methods**

#### Vehicle Self-Recovery:

- A. Release the winch drum and pull out the required length of cable.
- B. Whenever possible, pick an anchor point that aligns the winch cable to the vehicle's centerline as close as possible. This will help the spooling of the winch cable and reduce the load on the fairlead.
- C. Attach the winch hook to an anchor point.

## SAFE OPERATION - DRIVING SAFELY

**NOTE: If freeing a stuck vehicle by attaching to a tree, use an item such as a tow strap to avoid damaging the tree during winch operation. Sharp cables and chains can damage and even kill trees. Always respect the environment.**

- D. Re-engage the winch drum.
- E. Slowly winch in any slack in the winch cable, then damper it.
- F. Shift to the lowest gear available that will propel the vehicle in the direction of winching.
- G. Carefully apply winch power and throttle together to free the vehicle.

### CAUTION

**Using the vehicle throttle and winching at the same time has risk and is optional. Place the vehicle in neutral and use only the winch if unsure of your operating abilities.**

- H. Stop winching as soon as the stuck vehicle is able to propel itself without the help of the winch.
- I. Detach the winch hook, then rewind the cable evenly back onto the drum following the instructions in this manual.

### CAUTION

**The ONLY time a winch-equipped vehicle should be moving and using the winch is for self-recovery. The winch-equipped vehicle should NEVER use motion to “shock-load” the winch cable in an attempt to recover a second stuck vehicle. See ‘Winch Shock Loading’ section in this manual for more information.**

### **Recovery of Another Vehicle:**

- A. Release the winch drum and pull out the necessary length of cable.
- B. Attach the winch hook to the vehicle. Whenever possible, pick an anchor point on the stuck vehicle that aligns the winch cable to the winching vehicle’s centerline as close as possible. This will help the spooling of the winch cable and reduce the load on the fairlead.

## SAFE OPERATION - DRIVING SAFELY

### CAUTION

**Never attach the winch hook to a suspension component, brush guard, bumper or cargo rack. Vehicle damage may result. Always attach the hook to the strongest available portion of the vehicle frame or hitch.**

- C. Re-engage the winch drum.
- D. Slowly winch in any slack in the winch cable, then damper it.
- E. Shift to the lowest gear available on the stuck vehicle that will propel it in the direction of winching.
- F. Carefully apply winch power and the stuck vehicle's throttle together to free it.
- G. Stop winching as soon as the stuck vehicle is able to propel itself without the help of the winch.
- H. Detach the winch hook, then rewind the cable evenly back onto the drum following the instructions in this manual.

### **Winch Cable Care**

Always inspect your winch cable before each use for worn or kinked winch cable. Never use a cable that is damaged. Follow these guidelines for inspection and use:

- If equipped with a winch cable made of wire rope that is kinked, deformed, or bent is permanently and severely damaged. Promptly discontinue use of a winch cable in this condition.
- A kinked winch cable made of wire rope that has been “straightened out”, even though it may look usable, has been permanently and severely damaged. It can no longer achieve its load capacity rating. Promptly discontinue use of a winch cable in this condition.
- A winch cable made of synthetic rope should be inspected for signs of fraying. Replace the cable if fraying is observed. Promptly discontinue use of a winch cable in this condition.

## SAFE OPERATION - DRIVING SAFELY

- Replace synthetic winch cable if fused or melted fibers are discovered. The synthetic rope will be stiff and appear smooth or glazed in the damaged section. Promptly discontinue use of a winch cable in this condition.
- Never replace a synthetic winch cable with consumer-grade polymer rope. Only use cable that is specifically designed for winch use.
- Never grease or oil a wire rope winch cable. This will cause the cable to collect debris that will shorten the life of the cable.
- Never operate the winch with a damaged hook or latch. Always replace damaged parts before using the winch.

### **WARNING**

**Replace the winch cable and components at the first sign of damage to prevent SEVERE INJURY or DEATH in the event of failure.**

### **Winch Cable Spooling Guidelines**

After winching is complete, especially if winching at an angle, it may be necessary to respool the winch cable evenly across the drum. This reduces the chances of the winch cable “wedging” itself between lower layers of cable. You will need an assistant to perform this task:

- A. Release the winch drum.
- B. Pull out the winch cable that is wrapped unevenly onto the drum.
- C. Re-engage the winch drum.
- D. Have an assistant pull the winch cable hook strap tightly to apply about 100 lbs. (45 kg) of tension.
- E. Slowly winch the cable in while the assistant moves the end of the cable back and forth horizontally to evenly distribute it onto the drum.

## SAFE OPERATION - DRIVING SAFELY

### Winch 'Shock Loading'

Your winch (if equipped) is designed and tested to withstand the loads produced when operated from a stationary vehicle. Always remember that the winch, cable and components are NOT designed for shock loading. Follow these guidelines:

- Never attempt to “jerk” a load with the winch. For example, never take up cable slack by moving the winching vehicle in an attempt to move an object. This is a dangerous practice that generates high loads which may exceed the strength of the components. Even a slow moving vehicle can create a large shock load which can cause damage.
- Never quickly turn the winch ON and OFF repeatedly (“jogging”). This is a form of shock loading. This puts extra load on the winch components, the cable, and generates excessive heat in the motor and relay assembly.
- Never tow a vehicle or other object with your winch. Towing with a winch produces shock loading even when towing at slow speeds. Towing from the winch also positions the towing force high on the vehicle, which can cause vehicle instability and the possibility of an accident.
- Never use recovery straps with your winch. This is a form of shock loading. Recovery straps are designed to stretch and can store energy. Stored energy in the recovery strap is released if a failure occurs, making the event even more hazardous. Similarly, never use elastic “bungie” cords for winching.
- Never use the winch to tie down the vehicle to a trailer or other transporting unit. This is a form of shock loading that can cause damage to the winch components, the cable, or the transporting unit.

## MAINTENANCE

### Maintenance

Careful periodic maintenance will help keep your vehicle in the safest, most reliable condition. Inspection, adjustment, and lubrication of important components are explained in the maintenance schedule.

Inspect, clean, lubricate, adjust, and replace parts as necessary. When inspection reveals the need for replacement parts, always use genuine parts available from your dealer.

#### NOTE:

Periodic service and adjustments are critical. If you are not familiar with performing safe service and adjustment procedures, have a qualified dealer perform the required maintenance for you.

Pay special attention to the engine oil level during cold weather operation. A rise in engine oil level can indicate contaminants collecting in the oil sump or crankcase. Change oil immediately if the oil level begins to rise. Monitor the oil level, and if it continues to rise, discontinue use and determine the cause, or see your dealer.

### Severe Use Definition

CFMOTO defines severe vehicle use as:

- Frequent immersion in mud, water or sand
- Racing or race-style high RPM use
- Prolonged low speed, heavy load operation
- Extended engine idle
- Short trip cold weather operation
- Vehicles used in commercial operations

**For vehicles that are subjected to severe use, reduce all maintenance and service intervals by 50%.**

## MAINTENANCE

### WARNING

Procedures marked as '■' means if repair procedure is required, have an authorized dealer perform repairs that involve this component or system. Improperly performing the procedure could result in component failure and lead to serious injury or death.

### General Recommended Lubrication

Check all components at the intervals outlined in the Periodic Maintenance Schedule. Items not listed in the schedule should be lubricated at the general lubrication interval.

### Key Points Of Lubrication Schedule

- Change lubricants more often under severe use, such as wet or dusty conditions.
- Use All-Season Grease on pivot points.
- Lubricate every 500 miles (800 km), before long periods of storage, after pressure washing, or after submerging drive system.

Item	Lubricant	Method
Engine oil	SAE 5W-40, SP or higher API full-synthetic oil	Park the vehicle on a level surface, start the engine and idle for several minutes. Stop the engine and wait for a few minutes. The oil level should be located between upper and middle lines or at upper lines.
Brake fluid	DOT4	Maintain level between upper and lower lines
Front gear case oil	SAE 80W-90 GL-5	Oil capacity: 9.4 oz. (280 ml)
Suspension pivots and drivetrain	All-Season Grease	Grease gun - Pump grease until it begins to flow from the pivot point

## MAINTENANCE

### Pre-Ride Maintenance Checklist

Perform these inspections before operating the vehicle:

Item		Maintenance before operation			Remarks
		Hour	Calendar	Miles (km)	
■	Steering system	--	Pre-Ride	--	Visually inspect, test, or check components. Make adjustments and/or schedule repairs when required.
■	Throttle return	--	Pre-Ride	--	
	Front suspension and axles	--	Pre-Ride	--	
	Rear suspension and axles	--	Pre-Ride	--	
	Tires	--	Pre-Ride	--	
	Brake fluid level	--	Pre-Ride	--	
	Coolant level	--	Pre-Ride	--	
	Brake lever/foot brake function	--	Pre-Ride	--	
	Brake system function	--	Pre-Ride	--	
	Wheels/fasteners	--	Pre-Ride	--	
	Engine oil level	--	Pre-Ride	--	
	Transmission oil level	--	Pre-Ride	--	
▶	Air filter/Air box and connections	--	Pre-Ride	--	Visually inspect. Replace filter when dirty.

▶ = Severe Use Item. Inspect frequently on vehicles subjected to severe use.

■ = Have an authorized dealer perform repairs that involve this component or system.

● = Emissions related components. Have an authorized dealer perform repairs that involve this component or system.

## MAINTENANCE

Item		Maintenance before operation			
		Hour	Calendar	Miles (km)	Remarks
▶	Air box sediment tube	--	Pre-Ride	--	Inspect. If deposits are visible, clean intake tubes, air box, and replace air filter.
▶	CVT sediment tube	--	Pre-Ride	--	Inspect. If deposits are visible, drain / clean the CVT or have it serviced by a dealer.
■	Headlight aim / General lighting and turn indicators (if equipped)	--	Pre-Ride	--	Inspect. Adjust or replace lights when necessary.
▶	Radiator	--	Pre-Ride	--	Inspect for mud or debris blocking airflow. Clean surfaces when necessary.

▶ = Severe Use Item. Inspect frequently on vehicles subjected to severe use.

■ = Have an authorized dealer perform repairs that involve this component or system.

● = Emissions related components. Have an authorized dealer perform repairs that involve this component or system.

## MAINTENANCE

### Break-In Maintenance Checklist

Perform these maintenance items when the vehicle break-in is completed:

Item		Break-in Maintenance (Perform at the interval that arrives first)			
		Hour	Calendar	Miles (km)	Remarks
	General lubrication	20h	--	300 (500)	Lubricate all grease points, pivots, cables, etc.
	Engine oil/oil filter	20h	--	300 (500)	Change oil and filter.
▶	Engine air filter	20h	--	300 (500)	Inspect, replace if dirty, do not clean.
	Front gear case oil	20h		300 (500)	Check level. Inspect for leaks.
	Coolant	20h	--	300 (500)	Check level. Inspect for leaks.
	Transmission oil	20h	--	300 (500)	Inspect level.
▶	Brake pads/Brake discs	20h	--	300 (500)	Inspect brake pad and thickness of brake discs.

▶ = Severe Use Item. Reduce interval by 50% on vehicles subjected to severe use.

■ = Have an authorized dealer perform repairs that involve this component or system.

● = Emissions related components. Have an authorized dealer perform repairs that involve this component or system.

## MAINTENANCE

Item		Break-in Maintenance (Perform at the interval that arrives first)			
		Hour	Calendar	Miles (km)	Remarks
	Battery	20h	--	300 (500)	Check terminals. Clean and test battery condition as necessary.
■	Idle condition	20h	--	300 (500)	Inspect for proper rpm. See dealer for service if out of spec or erratic.
■	Steering/Wheel Alignment	20h	--	300 (500)	Inspect steering system. See dealer for service if wheel alignment is required.
▶	Foot brake/Hand brake (if equipped)	20h	--	300 (500)	Inspect function. Adjust as necessary.
■	Gear cases, CV shafts, Propshafts	20h	--	300 (500)	Inspect for leaks.
	Engine hoses, gaskets and seals	20h	--	300 (500)	Inspect for leaks.

▶ = Severe Use Item. Reduce interval by 50% on vehicles subjected to severe use.

■ = Have an authorized dealer perform repairs that involve this component or system.

● = Emissions related components. Have an authorized dealer perform repairs that involve this component or system.

## MAINTENANCE

### Periodic Maintenance Schedule

Perform maintenance at the interval that arrives first after the break-in period:

Item		Periodic Maintenance Intervals (Perform at the interval that arrives first)			
		Hour	Calendar	Miles (km)	Remarks
▶	Brake pads, brake disc	20h	Monthly	300 (500)	Inspect brake pad and thickness of the brake disc.
	Battery	200h	-	1800 (3000)	Check terminals. Clean and test battery condition as necessary.
	Engine hoses, gaskets and seals	20h	-	900 (1500)	Inspect for leaks.
▶	Air filter	100h	12M	900 (1500)	Always inspect pre-ride. Inspect frequently if subjected to severe use. Replace if dirty. Do not clean.
▶	CVT air intake filter screen / filter	50h	--	900 (1500)	Clean filter screen or filter, replace with new one if necessary.
▶	General lubrication	50h	3M	600 (1000)	Lubricate all grease points, pivots, cables, etc.

▶ = Severe Use Item. Reduce interval by 50% on vehicles subjected to severe use.

■ = Have an authorized dealer perform repairs that involve this component or system.

● = Emissions related components. Have an authorized dealer perform repairs that involve this component or system.

## MAINTENANCE

Item		Periodic Maintenance Intervals (Perform at the interval that arrives first)			
		Hour	Calendar	Miles (km)	Remarks
▶	Front gear case oil	100h	12M	1800 (3000)	Inspect level. Change yearly if hours or distance interval is not met.
▶	Engine oil / oil filter	100h	12M	1800 (3000)	Inspect for color change. Change if dirty. Change yearly if hours or distance interval is not met.
▶	Cooling system	50h	12M	900 (1500)	Pressure test system yearly.

▶ = Severe Use Item. Reduce interval by 50% on vehicles subjected to severe use.

■ = Have an authorized dealer perform repairs that involve this component or system.

● = Emissions related components. Have an authorized dealer perform repairs that involve this component or system.

## MAINTENANCE

Item		Periodic Maintenance Intervals (Perform at the interval that arrives first)			
		Hour	Calendar	Miles (km)	Remarks
▶	Radiator	20h	6M	300 (500)	Inspect, clean external surfaces. Clean more frequently if subjected to severe use.
■	Steering system	50h	6M	300 (500)	Inspect. Lubricate.
▶	Front suspension	50h	6M	300 (500)	Lubricate. Check fasteners and A-arm bushings. Replace A-arm bushings if worn or loose.
▶	Rear suspension	50h	6M	300 (500)	Lubricate. Check fasteners and swing arm bushings. Replace bushings if worn or loose.
▶	Gear shift	50h	1M	300 (500)	Inspect, lubricate, adjust as necessary.
▶ ■	Throttle body	100h	12M	1800 (3000)	Inspect. Clean carbon deposits. Inspect cable and lubricate frequently if subjected to severe use.

▶ = Severe Use Item. Reduce interval by 50% on vehicles subjected to severe use.

■ = Have an authorized dealer perform repairs that involve this component or system.

● = Emissions related components. Have an authorized dealer perform repairs that involve this component or system.

## MAINTENANCE

Item		Periodic Maintenance Intervals (Perform at the interval that arrives first)			
		Hour	Calendar	Miles (km)	Remarks
▶ ■	CVT drive belt	50h	6M	900 (1500)	Inspect. Replace as necessary. See dealer for service.
▶ ■	CVT drive and driven pulleys	50h	6M	900 (1500)	Clean and Inspect pulleys. Replace worn parts. See dealer for service.
	Fuel filter and hoses	100h	24M	1800 (3000)	Inspect routing condition. Replace filter and high-pressure hoses every 4 years.
	Cooling hoses	100h	--	900 (1500)	Inspect routing and condition.

▶ = Severe Use Item. Reduce interval by 50% on vehicles subjected to severe use.

■ = Have an authorized dealer perform repairs that involve this component or system.

● = Emissions related components. Have an authorized dealer perform repairs that involve this component or system.

## MAINTENANCE

Item		Periodic Maintenance Intervals (Perform at the interval that arrives first)			
		Hour	Calendar	Miles (km)	Remarks
●	Fuel system	100h	12M	600 (1000)	Inspect fuel tank, cap, fuel pump and fuel pump relay.
	Spark plug	200h	24M	3600 (6000)	Inspect. Replace if worn or fouled.
■	Engine mounts	100h	12M	900 (1500)	Inspect condition.
	Exhaust pipe and spark arrestor	100h	12M	900 (1500)	Inspect. Clean spark arrestor.
▶	Wiring, fuses, connectors, relays, and cables	100h	12M	900 (1500)	Inspect wire routing for wear, security. Apply dielectric grease as necessary to connectors subjected to water, mud, etc.

▶ = Severe Use Item. Reduce interval by 50% on vehicles subjected to severe use.

■ = Have an authorized dealer perform repairs that involve this component or system.

● = Emissions related components. Have an authorized dealer perform repairs that involve this component or system.

## MAINTENANCE

Item		Periodic Maintenance Intervals (Perform at the interval that arrives first)			
		Hour	Calendar	Miles (km)	Remarks
▶ ■	Wheel bearings	100h	12M	900 (1500)	Inspect for noise or looseness. Replace as necessary.
▶	Safety Belts	100h	12M	1800 (3000)	Visually inspect belts and test latches. Clean latch mechanism more often if used in severe conditions. Replace as necessary.
▶	Transmission oil	200h	24M	3600 (6000)	Inspect level. Change yearly if hours or distance interval is not met.
	Coolant	200h	24M	3600 (6000)	Change coolant every 2 years if hours or distance interval is not met.
▶	Brake fluid	200h	24M	3600 (6000)	Inspect fluid for color change. Change fluid every two years.

▶ = Severe Use Item. Reduce interval by 50% on vehicles subjected to severe use.

■ = Have an authorized dealer perform repairs that involve this component or system.

● = Emissions related components. Have an authorized dealer perform repairs that involve this component or system.

## MAINTENANCE

Item		Periodic Maintenance Intervals (Perform at the interval that arrives first)			
		Hour	Calendar	Miles (km)	Remarks
	Idle condition	--	12M	--	Inspect for proper rpm. See dealer for service if out of spec or erratic.
■	Steering / Wheel Alignment	--	12M	--	Inspect steering system. See dealer for service whenever steering parts or wheel alignment are required.
▶	Foot brake height	-	12M	-	Inspect. Replace brake pads or adjust height as required.
▶	Parking brake		12M	300 (500)	Inspect parking brake function. See dealer for service if tightness adjustment is required.

▶ = Severe Use Item. Reduce interval by 50% on vehicles subjected to severe use.

■ = Have an authorized dealer perform repairs that involve this component or system.

● = Emissions related components. Have an authorized dealer perform repairs that involve this component or system.

## MAINTENANCE

### Maintenance Procedures

#### Air Filter

Check and change the air filter at the intervals outlined in the Maintenance Schedule. The air filter element should be cleaned or replaced more often if the vehicle is used in extremely dusty or wet areas. Each time air filter maintenance is performed, check the air inlet of the air filter box for obstructions and debris. Check the air filter housing rubber joint to the throttle body and manifold fittings for an airtight seal. Check that all fittings are secure to avoid the possibility of unfiltered air entering the engine.

#### Air Filter Housing Inspection

Inspect the air filter for leaks. It is obvious if a layer of dust is on the clean side of the air filter. If there is damage, replace the air filter. Please eliminate any air leakage sources before installing a new air filter.

Clean the engine air filter, and bounce off the thick dust from the paper filter element to remove the soil and dust.

#### **NOTE:**

Do not use high pressure air to clean the air filter, which may destroy the paper fibers and reduce the filter function. If the air filter is dirty and hard to clean, replace it with a new one.

Wipe off the sealing surface of the filter and the inside of the outlet hose with a clean wet cloth. Make sure the sealing area of the outlet hose is intact.

Inspect the air filter housing for cleaning.

If a large amount of water is present in the air filter, have your dealer check for water entering the engine crankcase.

## MAINTENANCE

### Air Filter Maintenance

1. Remove the driver seat (Z10-4, remove the left rear passenger seat), release the clasps (1).
2. Pull up and remove the air filter access cover (2).
3. Release six clasps (3) and remove the air filter cover (4).
4. Remove the filter.
5. Inspect the paper filter element and confirm it is okay to be reinstalled, then brush away accumulated dust gently. Replace with new filter element if necessary.

<b>NOTE</b>
<b>Do not wash paper air filters.</b>

6. When reinstalling the air filter, inspect the sealing ring for dirt, oil or water deposits, and wipe it off with clean cloth.
7. Apply a layer of lubricating oil on the diameter of air filter rubber sealing ring, and reinstall it.
8. Install the air filter cover (4), verify proper installation and proper sealing.
9. Install the air filter access cover (2).

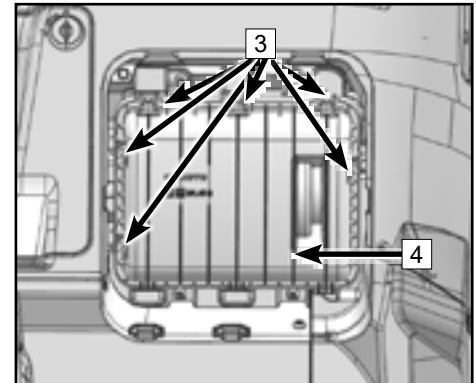
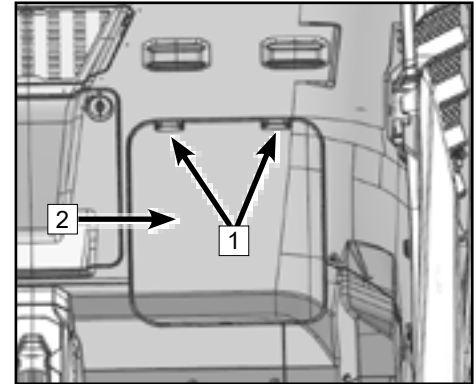

## MAINTENANCE

### Drying the Air Filter Housing after Submersion

If water has been ingested into the air filter housing, drain the air filter housing, remove the air filter, and thoroughly dry the components. Do not use compressed air on the paper air filter. Contact your dealer if vehicle performance issues exist.

#### CAUTION

**Do not operate the engine without an air filter element. Unfiltered air entering into the engine can cause engine wear and damage. Driving without an air filter will also decrease performance and can lead to engine overheating.**

**Major engine damage can result in the vehicle if water has been ingested into the air filter housing, and engine. Have the vehicle serviced by your dealer promptly if your vehicle becomes immersed or stalls in water that exceeds the footrest level. It is important to contact your dealer for service before starting the engine, as water may have been ingested in the air box and engine.**

## MAINTENANCE

### Engine

Always check and change the engine oil at the intervals outlined in the Maintenance Schedule. Change oil more frequently under severe use conditions.

### Engine Oil Level Check

With vehicle on a level surface, check the oil level as follows:

1. Place the vehicle in Park on a level surface.
2. Start the engine and idle for 1~2 minutes, then stop the engine.
3. Wait for 3~5 minutes.
4. Remove the oil dipstick **1** and wipe it with clean cloth.
5. Insert the dipstick **1** back into the dipstick hole, fitting the upper part of the oil dipstick with the hole face of the dipstick.
6. The oil level should be located at the middle upper line or be equal to the upper line. Replenish it if necessary.
7. After confirming the oil level, insert the dipstick **1** completely into the oil filler hole. Inspect for oil drips, and wipe them off with a clean cloth.

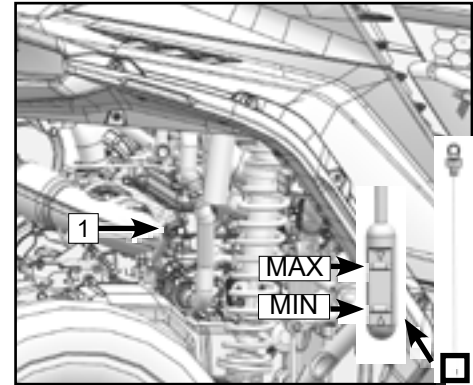

## MAINTENANCE

### Change the Engine Oil and Filter

1. Place the vehicle on a level surface.
2. Start the engine and allow it to idle for 2-3 minutes, then stop the engine.
3. Place an oil pan under the engine oil drain hole to collect the used oil (and the drained oil from the filter [2]).
4. Remove the oil dipstick, wipe it off with a clean cloth, and place it on the clean operation table.
5. Remove the magnetic drain bolt and washer [1] (located at the bottom rear of the vehicle), and drain the oil.
6. Remove the oil filter [2].
7. Make sure that the crankcase oil is drained completely.
8. Take a new oil filter (with an o-ring seal) and apply a fresh film of engine oil on the o-ring seal to lubricate it.
9. Install the engine oil filter and tighten it to the specified torque.

### Oil Filter Torque: 12.5 ft-lb. (17 N•m)

10. Clean debris and dirt from the magnetic drain bolt, and replace the washer if necessary.
11. Install the magnetic drain bolt and washer [1].

### Drain Bolt Torque: 25.8 ft-lb. (35 N•m)

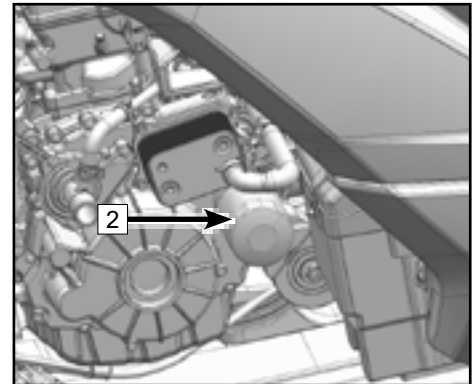
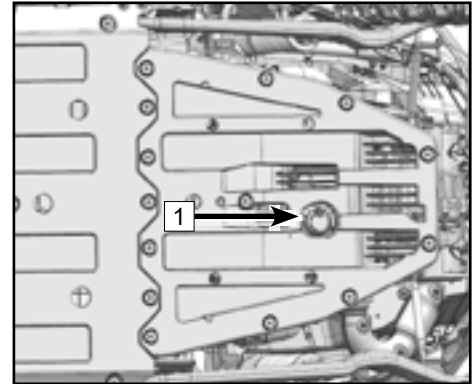

## MAINTENANCE

12. Wipe the drain bolt and engine oil filter area with a clean cloth.
13. Replenish with recommended oil to the specified level with the supplied funnel at the dipstick fill hole.
14. Insert the oil dipstick **3** into the oil filler hole, fit the upper part of the oil dipstick with the hole face of the dipstick.
15. Park the vehicle on a level surface, start the engine, idle for 1-2 minutes and stop the engine. Wait for 3-5 minutes. The oil level should be located at the middle upper line or equal to the upper line.

### NOTE

Engine oil level should be kept at the proper level, or it will affect the engine operation.

16. Insert the oil dipstick **3** into the oil filler hole completely.
17. Verify the vehicle is parked, start the vehicle, and idle it for 30 seconds.
18. Inspect for oil leaks after stopping the engine. If leaks appear, see your dealer.

### WARNING

**Ensure that the vehicle is turned off and parked during maintenance to avoid vehicle damage or personal injury.**

19. Properly dispose the used oil and filter.

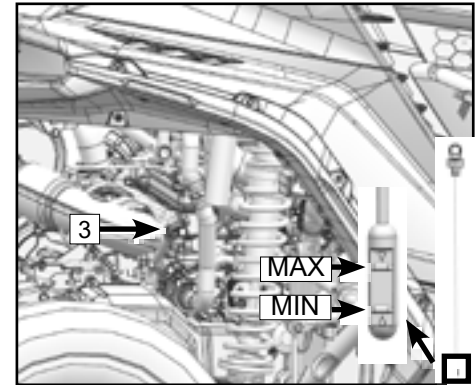

## MAINTENANCE

### Transmission Oil Check

**NOTE: The transmission and rear drive gear share one case.**

1. Place the vehicle on a level surface and park it.
2. Inspect the view window **1** for the proper oil level **A**.
3. If the oil level is lower than **A**, unscrew the oil cap **2**, and use the supplied funnel to replenish the recommended oil to area **A**.
4. Tighten the oil cap **2**, inspect for oil drips, and if any, wipe it off with a clean cloth.

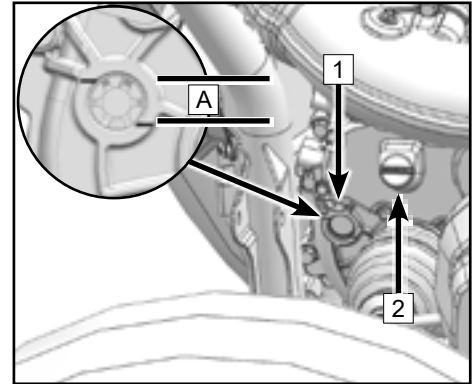

## MAINTENANCE

### Transmission Oil Replacement

1. Place the vehicle on a level surface and park it.
2. Stop the engine and power off the vehicle.
3. Place an oil pan under the oil drain hole (1) of the engine transmission to collect the used oil.
4. Unscrew the oil filling port bolt plug.
5. Remove the magnetic drain bolt and washer (2), and drain the oil.
6. Verify the transmission oil is drained completely.
7. Clean the debris and dirt from the magnetic drain bolt and washer (2). A new washer should be replaced every time when changing transmission oil.
8. Install the magnetic drain bolt and washer.

### Drain Bolt Torque: 25.8ft-lb. (35 N•m)

9. Dry the area around the magnetic drain bolt with a clean and dry cloth.
10. Add the recommended type and amount of oil (SAE75W-90 GL-5) into the fill hole (3) of the transmission oil using the funnel, funnel extension tube and adapter. Keep oil level in the specified range.
11. After 5 minutes, inspect the oil level at the view window, and adjust the oil amount as necessary.

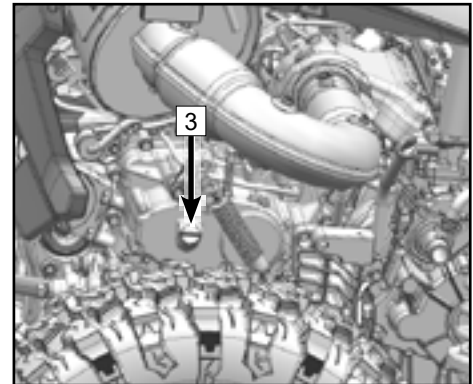
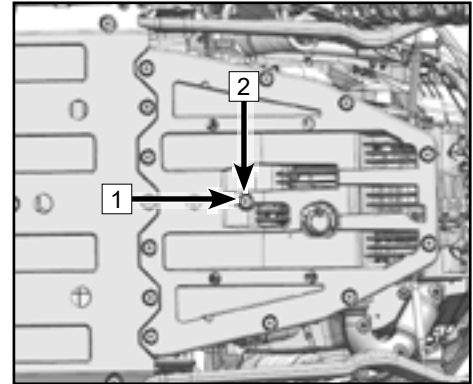

## MAINTENANCE

### NOTE

Too much or too little oil will have an impact on the normal operation of the engine. Make sure the oil is maintained at the proper level.

12. Install and tighten the oil filling port bolt plug.
13. Inspect the gear case for leaks. Contact your dealer if a leak is found.

### WARNING

**Ensure that the vehicle is turned off and parked during oil replacement to avoid personal injury.**

14. Properly dispose the used gear oil.

### Engine Idle Speed

This vehicle is equipped with an electronic fuel injection system. The throttle body is a vital part of the fuel system which requires very sophisticated adjustment, and was set at the factory. There are no consumer provisions to adjust engine idle speed. If the settings are disturbed, poor engine performance and damage may result. Check the engine idle speed for stability or an abnormal engine idle condition and contact your dealer for service if necessary.

### NOTE

Engine Idle Speed: 1200  $\pm$ 50 rpm

## MAINTENANCE

### Front Gear Case

The front and rear gear case must be inspected for oil leaks before operating. If any leaks are found, have your dealer check and repair the vehicle.

#### Front Gear Case Inspection

Due to the design of the gear case, the oil level cannot be observed from the filling port. Drain the oil and add the specified amount of oil into the gear case.

#### Replace the front gear case oil

1. Place the vehicle on a level surface and park it. Stop the engine.
2. Place an oil pan under the front gear case to collect the used oil.
3. Lift up the vehicle with a jack to a proper position and support it.
4. Remove five wheel nuts **1**, and remove the front right wheel **2**.
5. Remove the filler bolt **3** and the magnetic drain bolt and washer **4** at the bottom of the gear case, then drain out the oil.

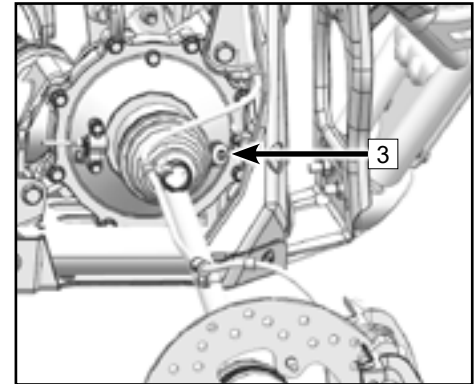
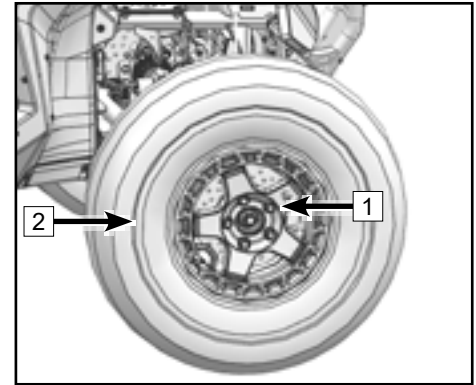

## MAINTENANCE

6. Drain out the oil completely, then reinstall the drain bolt **4** and tighten it to the specified torque.

**Drain Bolt Torque: 18.4 ft-lb. (25 N•m)**

7. Replenish the gear oil with the specified amount.

**Front Gear Case Oil Capacity: 9.4 oz. (0.28 L)**

8. Install the filler bolt and tighten it to the specified torque.

**Bolt Torque: 18.4 ft-lb. (25 N•m)**

9. Install the front right wheel **2**. Finger-tighten five wheel nuts **1**, then tighten the nuts **1** diagonally to the specified torque.

**Wheel Nut Torque: 81.1 ~ 88.5 ft-lb. (110 ~ 120 N•m)**

10. Inspect the front gear case for leaks. Check for reasons if leaks are found.

### CAUTION

**Prevent foreign objects from falling into the gear case when adding oil.**

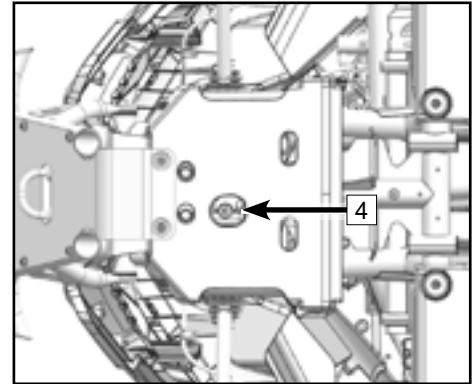

## MAINTENANCE

### Front and Rear CV Drive Shaft

#### Front and Rear CV Axle Boots

The front and rear axle boots 1 must be checked for holes or wear before operating. If any damage is found, have your dealer repair the vehicle.

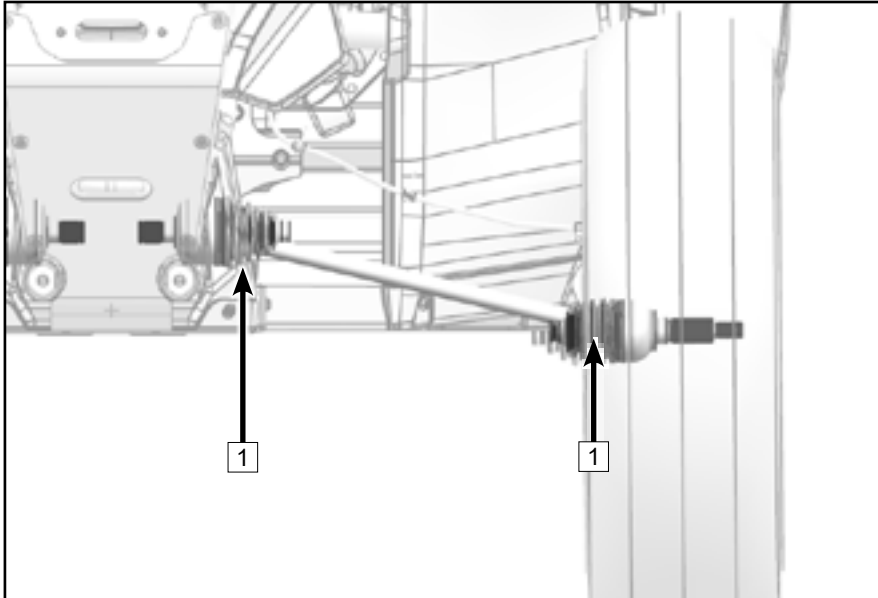

## MAINTENANCE

### Cooling System

#### Coolant Level Inspection

1. Place the vehicle in Park on a level surface. Stop the engine and turn off the vehicle power.
2. Wait for the engine to cool down to ambient temperature, then inspect the coolant level.
3. Inspect the coolant level in the expansion tank is between the upper and lower marks through the hole (1).
4. When the coolant level is lower than the lower limit, replenish the coolant (see the serial numbers 1-6 from 'Changing the coolant' for details).
5. Add coolant to the middle of the upper and lower limits (up to the 'MAX' line).
6. Tighten the expansion tank cap. Install the parts in the reverse order of removal and restore the vehicle.

#### **⚠ WARNING**

**If water is added, contact your dealer to inspect the antifreeze content of the coolant as soon as possible.**

**Distilled water can be used for a short time if coolant is not available, softened tap water could be a second choice. Never add hard water or salt water, as it is harmful to the cooling system.**

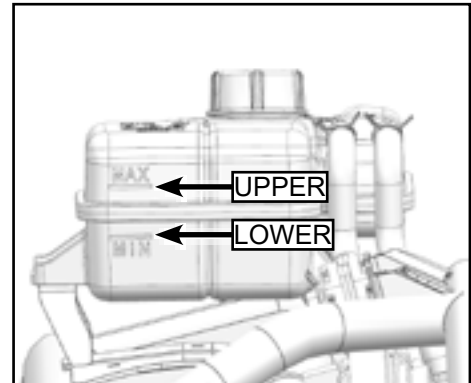
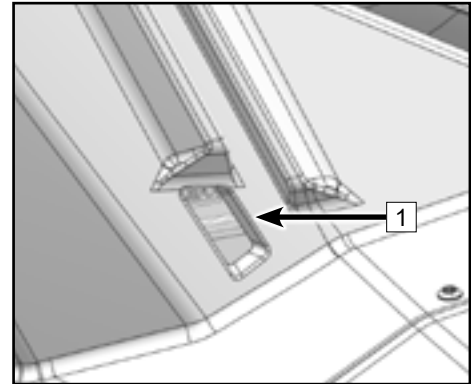





## MAINTENANCE

### Changing the Coolant

#### **WARNING**

If the engine was running before or is still running, do not remove the expansion tank cap. It is necessary to shut down the engine and wait until the engine cools completely. To avoid being scalded by coolant, wear gloves or cover with a thick towel when opening the expansion tank cap. Loosen the expansion tank cap for two turns to release the pressure, then remove it.

1. Place the vehicle on a level surface and park it.
2. Remove the cab joint protector .
3. Remove the outer fixing bolts .
4. Remove the inner fixing bolts .
5. Remove the upper RH filler panel assembly .

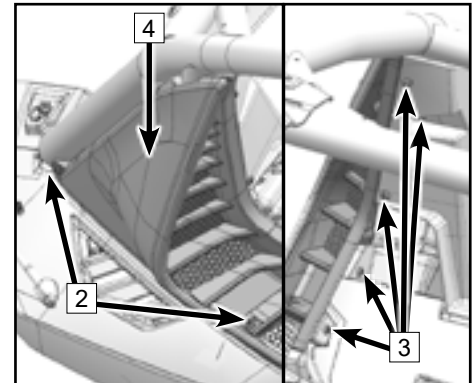
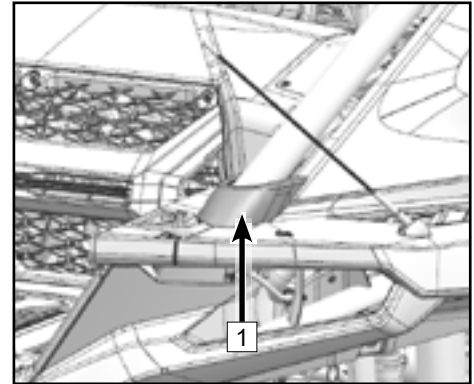

## MAINTENANCE

6. Remove the expansion tank cap [5].
7. Place a pan under the inlet hose of the engine [6] to collect the coolant.
8. Release the clamp [7] backwards, then pull the inlet hose from the engine [6] to drain the coolant.
9. After draining the system, install the inlet hose on the engine [6]. Then tighten the clamp securely [7].

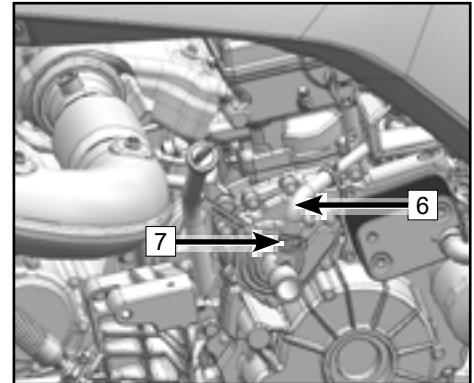
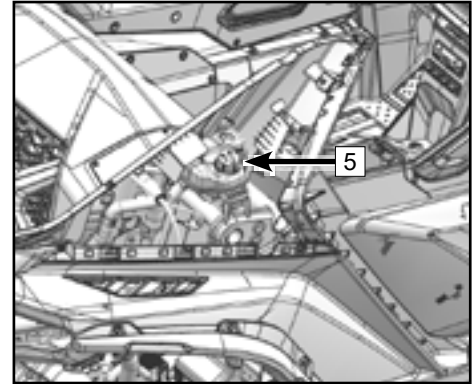

## MAINTENANCE

10. Open the expansion tank cap [8] and replenish the coolant to “MAX” level line of the expansion tank.

11. Start the vehicle, idle the engine for 60 seconds (do not cover the expansion tank cap during the warm up), and inspect the engine removal pipe and the exhaust port [9] of the expansion tank for coolant flow. Cover the expansion tank cap.

12. Start the engine and allow it to idle until the cooling fan starts, then turn off the engine.

13. Wait until the engine cools down, then verify the fluid level at the expansion tank to ensure it is between the ‘MIN’ and ‘MAX’ lines. Replenish the coolant if the coolant is insufficient.

14. Inspect the cooling system for leaks. If any are found, contact your dealer to inspect it.

15. Tighten the expansion tank cap. Install the parts in the reverse order of removal and restore the vehicle.

16. Properly dispose the used coolant.

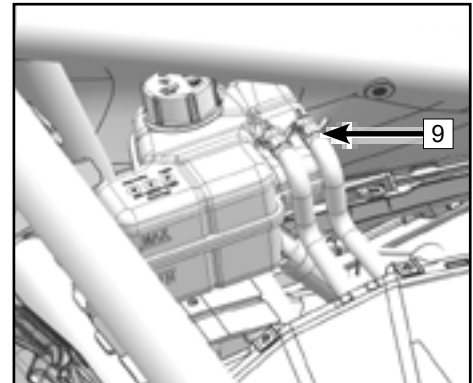
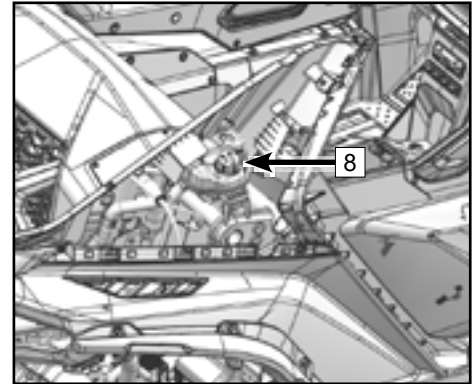

## MAINTENANCE

### **Recommended Antifreeze:**

Any high quality ethylene glycol antifreeze containing corrosion inhibitors for aluminum engines.

CFMOTO Recommended Coolant Freeze Protection Level: **-31°F (-35°C)**

Antifreeze / Distilled Water Mix Ratio: **1:1**

Z10 / Z10-4:

Coolant total capacity (add the antifreeze between the upper and lower lines of the expansion tank):

**4.2 qt. (4 L)**

Coolant change: **4.2 qt. (4 L)**

Coolant expansion tank capacity: expansion tank capacity: **MIN line - 10.1 oz. (0.3 L), MAX line - 23.7 oz. (0.7 L), Total capacity - 1.05 qt. (1L)**

### **Cleaning the Radiator**

Clean the front and back external surfaces of the radiator if it is covered with mud or debris to ensure it continues to efficiently cool the engine. Use only low pressure water to clean the radiator. High pressure washers can damage components.

## MAINTENANCE

### Spark Plug

The spark plug is an important engine component that is easy to inspect. The color and condition of the spark plug can indicate the condition of the engine. The ideal color on the insulator around the center electrode is a medium-to-light tan color for an engine that is being operated normally. If electrode erosion becomes excessive, or if carbon and other deposits are excessive, you should replace the spark plug with the specified plug.

Periodically remove and inspect the spark plug(s) for heat damage and deposits that will cause them to break down and erode. Do not attempt to diagnose spark plug color or engine problems yourself. Instead, take the vehicle to your dealer for service.

### Spark Plug Removal and Inspection

1. Inspect the rear service cover **1**.
2. Clean dirt or deposits from the ignition coil and cylinder area.
3. Unplug three ignition coil connectors, remove the bolts **2**, then remove the ignition coils **3**.

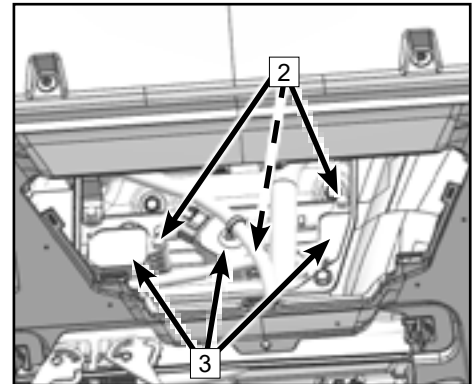
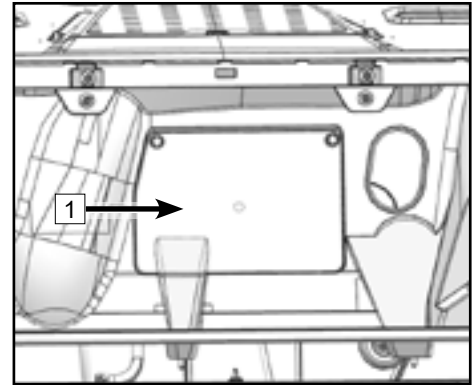

## MAINTENANCE

- Remove the spark plug [5] with the spark plug socket [4] and wrench from the tool kit.
- Check the spark plug gap (a) using a thickness gauge. Adjust the gap if necessary.

Spark Plug Type: **TORCH BN8RTI**

Spark Plug Gap [a]: **0.031 ±0.004 in. (0.8 ±0.1 mm)**

### **WARNING**

The installed sequence of the ignition coil connectors are particularly important. If they are installed incorrectly, this will result in incorrect ignition sequence and spark timing, which can lead to improper combustion, misfire, and shuddering. This will lead to reduced engine output power, increased fuel consumption, and engine failure may occur. Please record the sequence of the ignition coil connectors before removing them.

### Installation

- Clean the gasket surface. Wipe off any grime from the threads.
- Install the spark plug and tighten it to the specified torque.
- Install the ignition coil [3], and the bolt [2], then plug in the ignition coil connector [1].

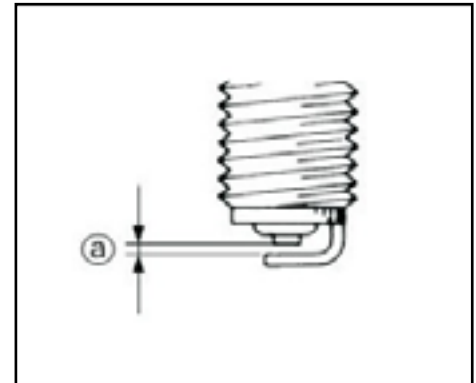
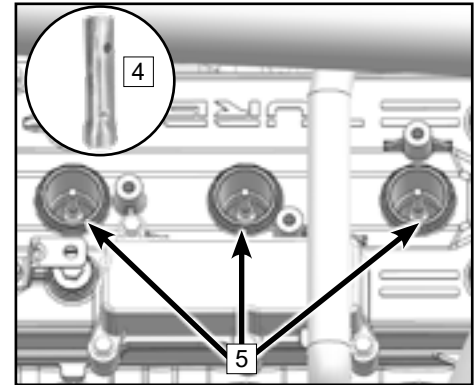

## MAINTENANCE

Spark Plug Torque: **10.3 ±1.5 ft-lb. (14 ±2 N•m)**

### NOTE

If a torque wrench is not available when you are installing a spark plug, a good estimation of the correct torque is to tighten the spark plug by finger first, then use the tool to tighten 1/4 to 1/2 turn. Tighten to specified torque as soon as possible.

### Spark plug removal to expel water from the engine

If water has been ingested into the engine, it is important to remove the water as soon as possible by removing the spark plug(s) and using the starter system to rotate the engine for a short period to expel water out of the cylinder(s). Verify that the air box has been drained of water before attempting to expel water. Have a dealer service the engine immediately.

### CAUTION

**Major engine damage can result in the vehicle if water is ingested into the engine. Have the vehicle serviced by your dealer promptly if your vehicle becomes immersed or stalls in water that exceeds the footrest level. It is important to contact your dealer for service before starting the engine if water has been ingested. Water inside the engine can cause a 'hydraulic lock' effect that can damage the starter and engine components. The engine oil should be checked for water contamination. Drain and refill with new engine oil if water is found in the crankcase.**

## MAINTENANCE

### Exhaust Spark Arrestor

Clean the carbon deposits from the spark arrestor periodically. Blocked spark arrestor will decrease the engine power. After driving through mud or water, inspect the spark arrestor and clean it if necessary.

**⚠ WARNING**

**Ensure that the exhaust system is fully cooled before servicing the spark arrestor.**

1. Remove the nuts and washers [1].
2. Remove the spark arrestor [2].
3. Use a wire brush to gently remove carbon deposits from the wire mesh [3] of the spark arrestor.
4. Clean inside the spark arrestor with compressed air.
5. Inspect for damage or wear to the wire mesh of the spark arrestor. Replace with a new spark arrestor if damaged or worn.
6. Reinstall the spark arrestor, washers and nuts onto the muffler.

**Torque: 7.4 ft-lb. (10 N•m)**

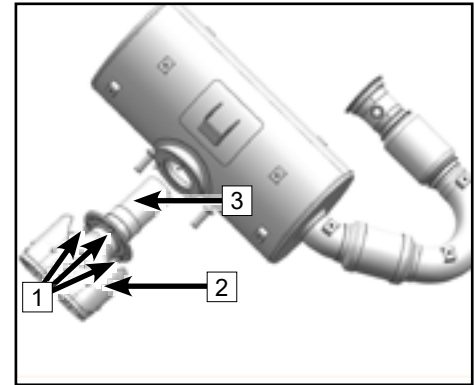

## MAINTENANCE

### Battery

This vehicle is equipped with a 12 volt/32 Amp-hour, sealed maintenance-free colloidal lead-acid battery. Therefore, it is not necessary to check the electrolyte or add distilled water to the battery. If the battery seems to have discharged or the housing is damaged, consult your dealer.

If the vehicle will not be used for more than 2 months, store the battery in a dry and cool place. To ensure optimum service life of the battery, keep the battery charged properly to ensure the battery has reserve capacity available at the starter motor. When the vehicle is used frequently, the battery charge is maintained by the charging system.

#### CAUTION

**To avoid battery damage and power loss, do not leave the vehicle powered on for more than 20 minutes. Otherwise, the vehicle may not start. If this happens, remove the battery and charge it.**

Batteries self-discharge from infrequent use. The rate of self-discharge speed varies with battery type and ambient temperature. When environment temperature rises for example, the rate of discharge could increase by a factor of 1 for every 60°F (15°C) temperature rise.

#### Battery sulphation

A common battery failure is sulphation. When the battery is low on power for a long time, electrolyte can sulphate the battery. Sulphation is an abnormal product produced by chemical reaction in the battery. If sulphation occurs, battery discharging can cause permanent battery plate damage and cause it to be impossible to charge. When such a fault occurs, the only resolution is to replace the battery with a new one.

#### Battery maintenance

Always keep the battery fully charged, or it may damage the battery.

If the vehicle is driven infrequently, inspect the battery voltage weekly with a voltmeter. If it drops below 12.0 volts, the battery should be charged (contact your dealer for inspection). Do not use an automotive quick-charger that may overload the battery and damage it.

## MAINTENANCE

Clean the battery housing with a soft brush dipped in a mixture of baking soda and water.

Use a wire brush to remove the corrosion from the positive and negative lug plates.

Use the required battery charger (constant low voltage/amp) to recharge a low-maintenance battery. Using traditional high-amperage battery chargers will reduce battery life.

For vehicles not used within 30 days (in-car battery), charge the battery monthly or connect the battery to the trickle charger (battery maintainer).

The battery must be removed from the vehicle when it is being charged.

### **Battery charger**

Contact your dealer for proper battery charger specifications.

### **Battery charging**

Remove the battery from the vehicle.

Connect the charger wires, and ensure that the charging current is 1/10 A of the battery capacity. For example, if the battery capacity is 10 Amp-hour, its charging current should be 1 ampere.

Ensure that the battery is fully charged before reinstalling.

<b>NOTE</b>
The charging current of the charger is at most 10% of the battery capacity.

 <b>WARNING</b>
<b>Do not remove the battery sealing strip, or the battery will be damaged. Do not mount an ordinary wet-cell battery in this vehicle, or the electrical system may not work properly.</b>
<b>When removing the battery, disconnect the negative pole, then the positive pole. During installation, the connection sequence of positive and negative is opposite of disassembly.</b>

<b>NOTE</b>
When charging a maintenance-free battery, always follow the instructions in this manual.

## MAINTENANCE

### Battery removal

Place the vehicle on level ground and park it.

Stop the engine. Put the vehicle ignition system in a completely power-off state.

Remove the passenger seat (Z10-4, remove the second row passenger seat).

Remove the black negative wire (-).

Remove the red positive wire (+).

Remove the battery belt.

Remove the battery.

### Battery installation

Place the vehicle on level ground and park it.

Stop the engine. Put the vehicle ignition system in a completely power-off state.

Place the battery.

Install the battery belt.

Install the red positive wire (+).

Install the black negative wire (-).

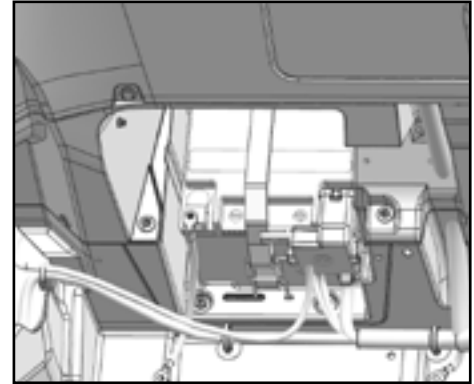

## MAINTENANCE

### WARNING

**Avoid direct contact with the skin, eyes and clothing. Always protect eyes when working near the battery. Keep the battery out of reach of children. Keep the battery away from sparks, open flames, cigarettes, or other ignition points. When using or charging batteries in a confined space, ventilate the area.**

**Battery acid detoxification treatment:**

**External: Rinse the touched area with clean water.**

**Internal: See a doctor immediately.**

**Eyes: Rinse the eyes with clean water for 15 minutes and see a doctor immediately.**

### CAUTION

**Improper disassembly and assembly of positive and negative wires may lead to a short circuit between the battery and the vehicle body.**

## MAINTENANCE

### Brakes

#### Brake Fluid Level Inspection

Before riding, check that the brake fluid level is above the low mark and replenish whenever necessary. The brake fluid reservoir **1** is under the front access panel. Insufficient brake fluid may let air enter the brake system, possibly causing the brakes to become ineffective.

#### Observe These Precautions:

- When checking the fluid level, verify the vehicle is on a level surface.
- Use only the designated quality brake fluid. Otherwise, rubber seals may deteriorate, causing leaks and poor brake performance.
- Recommended brake fluid: DOT 4.
- Refill with the same type of brake fluid. Mixing fluids may result in a harmful chemical reaction and may lead to poor brake performance.
- Be careful that water does not enter the master cylinder reservoir. Water will significantly lower the boiling point of the fluid and lead to poor brake performance.
- Brake fluid may deteriorate painted surfaces or plastic parts. Always clean up spilled fluid immediately.

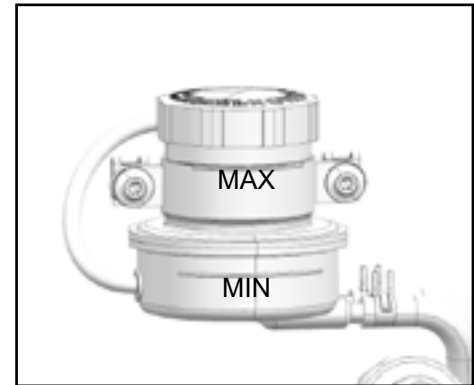
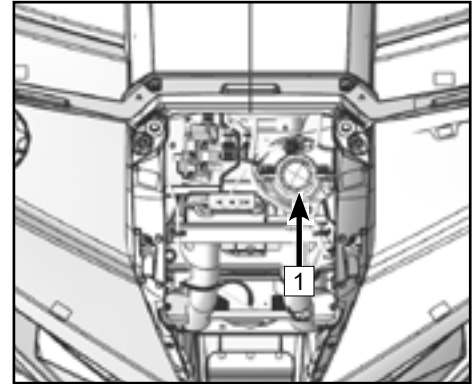

## MAINTENANCE

- As the brake pads wear, it is normal for the brake fluid level to gradually go down. A low brake fluid level may indicate worn brake pads or brake system leakage. Therefore, be sure to check the brake pads for wear before checking the brake system for leakage.
- Contact your dealer if the brake fluid level goes down unexpectedly.

### Brake Pad Inspection

Inspect the front and rear brake pads and discs for damage and wear. If the pad thickness **A** is less than 0.236 in. (6.0 mm) or the disc thickness **B** is less than 0.26 in. (6.5 mm), have your dealer replace them. Replacement of brake components requires professional knowledge. These procedures should be performed by your dealer.

#### NOTE:

Wheels must be removed to check brake pads.

#### WARNING

##### After service:

**Make sure the brakes operate smoothly and that the pedal free travel is correct.**

**Make sure the brakes do not drag and the brake operation is not spongy.**

**All air is bled from the brake system.**

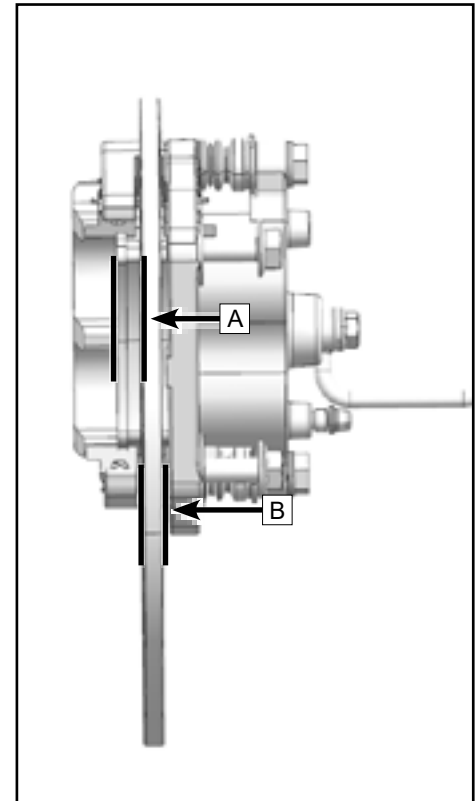

## MAINTENANCE

### Brake Fluid Change

Complete brake system fluid replacement should be performed only by trained service personnel. Have your dealer replace the following components during periodic maintenance, or when they are damaged or leaking:

- Replace the brake hoses every four (4) years.

#### WARNING

**An over-full brake reservoir may cause brake drag or brake lockup, which could result in an accident causing serious injury or death. Maintain brake fluid at the recommended level. Do not overfill.**

#### WARNING

**Never store or use a partial bottle of brake fluid. Brake fluid is hygroscopic, meaning it rapidly absorbs moisture from the air. The moisture causes the drop of boiling temperature of the brake fluid, which can lead to early brake fade and the possibility of accident or severe injury. After opening a bottle of brake fluid, always discard any unused portion.**

### Brake Light Switch Operation

The brake light switch is activated by foot brake pedal pressure, and is properly working when the brake light comes on just as braking takes effect. Check that the switch assembly or the electrical circuit is working properly in case of brake light failure.

### Suspension

Some suspension components of the vehicle do not require maintenance or lubrication. Ensure these components are cleaned regularly, and are not loose or damaged before operating the vehicle.

## MAINTENANCE

### Suspension

#### Front Swing Arm Bushing and Rear Sway Bar Lubrication

Lubricate the swing arm bushings of the front suspension and the sway bar of the rear suspension.

- Add grease into grease nipples **1** with a grease gun until grease lightly flows from the bushings.

**NOTE: The grease nipples of swing arm bushing and sway bar are symmetrical. There are 12 grease nipples in total.**

#### Front Suspension Pivot Lubrication

- Lubricate the upper and lower pivots of the front suspension:
- Add grease into the upper and lower pivot grease nipples **1** with a grease gun until grease lightly flows from the bushings.

#### Rear Sway Bar Lubrication

- Add grease into the upper and lower pivot grease nipples **2** with a grease gun until grease lightly flows from the bushing.

#### NOTE:

Recommended grease type: All-season grease

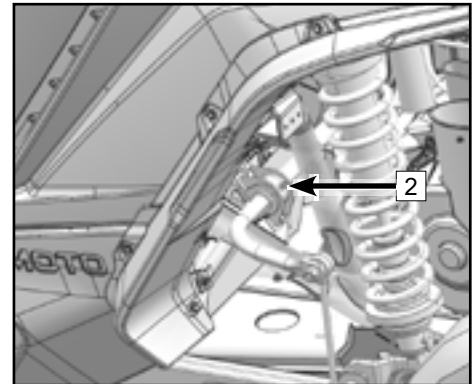
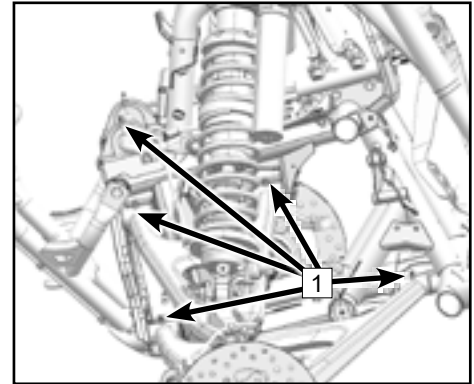

## MAINTENANCE

### Shock Absorbers

#### Shock Preload Adjustment

Proper shock settings are a personal preference, and changes with rider weight, riding style and terrain.

When riding on rough terrain conditions, towing, or carrying the maximum weight of people and cargo, increase the spring preload to get firmer riding. Decrease the spring preload as necessary for rough or soft terrain to get smooth riding.

**NOTE:** Elevate the vehicle with the tires off the ground to assist with adjustments. Always adjust the left and right shock absorbers to the same setting with proper tool.

#### Increase spring preload:

Loosen the lock nut **1**.

Turn the adjuster **2** clockwise to shorten the spring length.

Re-tighten the lock nut **1**.

#### Decrease spring preload:

Loosen the lock nut **1**.

Turn the adjuster **2** counterclockwise to increase the spring length.

Re-tighten the lock nut **1**.

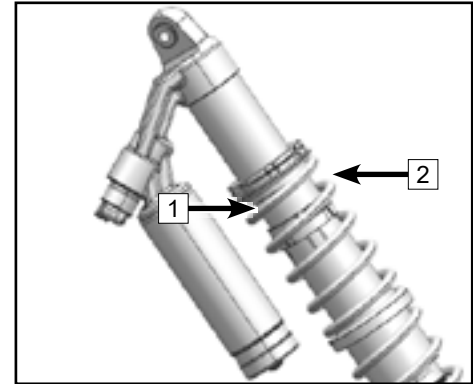

#### NOTE

Wrenches are included in the tool kit for adjusting shock absorber spring preload. Always adjust the left and right shock absorbers to the same setting.

## MAINTENANCE

### Wheels

#### Tire Pressure

Inspect the tire pressure with a tire gauge before operation:

##### **Z10:**

Front: 21.8 Psi (150 kPa)

Rear: 21.8 Psi (150 kPa)

When fully loaded, front: 21.8 Psi (150 kPa)

When fully loaded, rear: 24.6 Psi (170 kPa)

##### **Z10-4:**

Front: 21.8 Psi (150 kPa)

Rear: 21.8 Psi (150 kPa)

When fully loaded, front: 21.8 Psi (150 kPa)

When fully loaded, rear: 27.5 Psi (190 kPa)

#### Tread Depth

Inspect the tread depth regularly and replace the tires if the minimum tread depth is less than specified.

**Minimum Tread Depth (A): 3/32 in. (3.0 mm)**

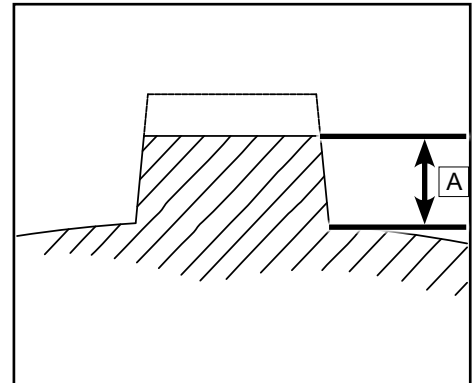
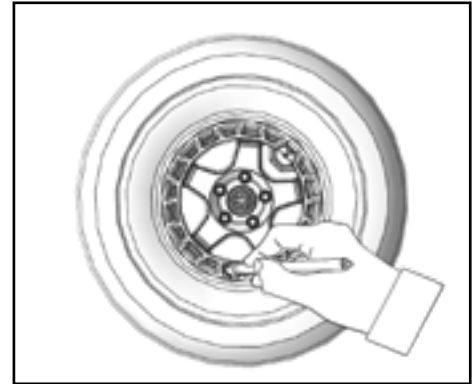

## MAINTENANCE

### Wheel Bearings

- Lift the vehicle with a jack and support it securely under the frame with the tires off the ground.
- Push and pull the wheels at the outer edges to feel for side play or looseness. See your dealer if there is any side play or looseness.

### Wheel Replacement

#### Removal

- Place the vehicle on level ground.
- Lift up the vehicle off the ground with a jack and support it.
- Remove five wheel nuts **1**.
- Remove the wheel.

#### Installation

Place the wheel into the wheel bracket in the right direction and pre-tighten it with wheel nuts.

Tighten the wheel nuts to the specified torque.

#### **Wheel Nut Torque: 81 ~ 88 ft-lb. (110 ~ 120 N•m)**

Remove the vehicle bracket and place the vehicle on the ground stably.

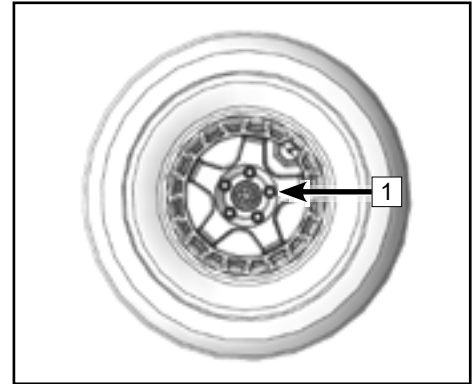

# MAINTENANCE

## Electrical

### Fuse Box / Main Fuse / EPS fuse

The fuse box (1) is located at the ECU side behind the passenger seat (Z10-4 , located at the ECU side behind the second row of the passenger seat). If a fuse is blown, turn off the main switch and install a new fuse of the specified amperage. Turn on the vehicle power. If the fuse immediately blows again, contact your dealer.

Electronic relays facilitate the operation of various vehicle system functions. These relays are also located in the box. Contact your dealer to replace or diagnose.



**WARNING**

**To prevent an accidental short-circuit, turn off the vehicle before checking or replacing fuses. Always use a fuse with the correct specified rating. Never use conductive material in place of the proper fuse. Using an improper fuse can cause damage to the electrical system and may lead to a fire.**

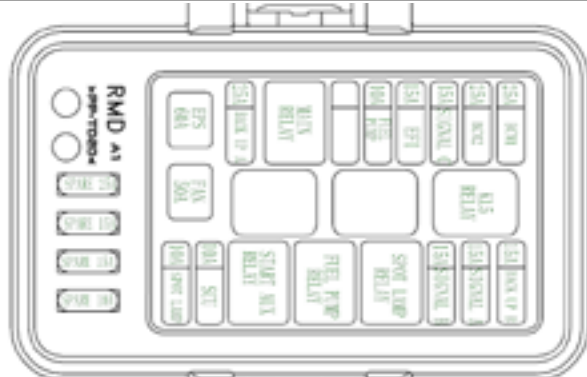
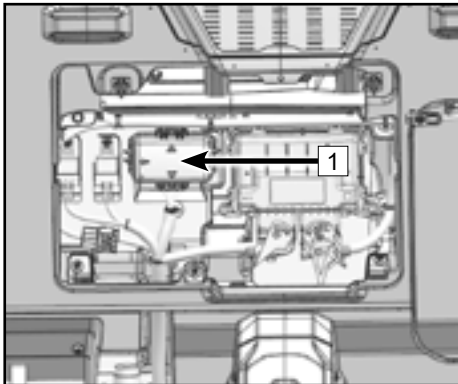

## MAINTENANCE

### Headlight Adjustment

To adjust the headlight:

Turn the high beam adjustment knob (1) to adjust the high/low beam direction vertically.

Turn the low beam adjustment knob (2) to adjust high/low beam direction horizontally.

#### WARNING

**Adjustment of high/low beams should be in accordance with local regulations. The standard is based on light emitted with the front and rear wheels on the ground and the rider sits in the vehicle. It is advisable to have your dealer perform headlight adjustments. Improper adjustment could lead to an accident resulting in serious injury or death.**

#### NOTE:

Dirt and/or debris can collect in the gap between the headlights and the front panel, especially after driving in muddy terrain. It is recommended to remove the front panel when washing and cleaning the vehicle. Make sure to clean thoroughly.

### Lighting Replacement

The headlight and taillight are LED assemblies. Have your dealer replace the entire assembly if an LED is damaged or has failed.

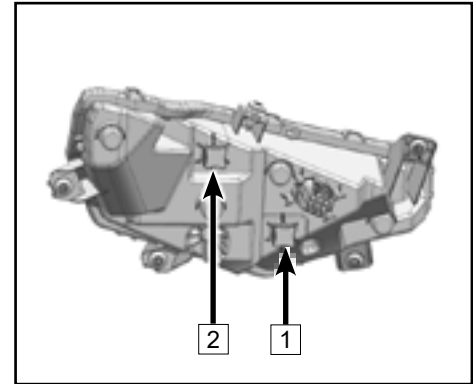

## MAINTENANCE

### Safety Belts

All seat belts should be inspected for proper operation before using the vehicle:

1. Insert the latch plate into the buckle until a click sounds. The latch plate must slide smoothly into the buckle. The click sound indicates that it has been securely locked.
2. Press the red unlock button in the middle of the buckle to ensure it can be unlocked smoothly.
3. Pull each seat belt completely out and check the full belt for damage, including cuts, wear, or stiffness. If any damage is found, or the seat belt is not operating properly, inspect or replace the entire seat belt system by the dealer or a qualified person.
4. Clean the harness from dirt or debris and scrub the harness with mild soap water. Do not use bleach, dyes, or household detergents. Rinse the entire harness. Use a garden hose to regularly rinse the buckle 2 and retractor housing.

## CLEANING & STORAGE

### Cleaning and Storage

#### Washing the Vehicle

Keeping your vehicle clean will not only improve its appearance, but it can also extend the life of various components. With a few precautions, your vehicle can be cleaned much like an automobile:

- The best and safest way to clean your vehicle is with a garden hose and a pail of mild soap and water. Harsh detergents may deteriorate rubber components.
- Use a professional type washing mitten, cleaning the upper body first and the lower parts last.
- Pay special attention that the cooling system radiator and axle boots are thoroughly cleaned of all dirt and debris.
- Rinse with water frequently and dry the vehicle with a chamois to prevent water spots.
- Lubricate all pivot points immediately after washing.
- Allow the engine to run for a while to evaporate any water that may have entered the engine air intake or exhaust system.

CFMOTO does not recommend the use of a high pressure type car wash system for washing your vehicle, as water can be forced past seals and damage decals. If a high pressure system is used, exercise extreme care to avoid water damage to the decals, wheel bearings, transmission seals, body panels, brakes, warning labels, air filter, air filter intake system and electrical system. Ensure water is not allowed to enter into the air filter or CVT housing. If warning and safety labels are damaged, contact your dealer to purchase a replacement.

## CLEANING & STORAGE

### Waxing the Vehicle

Your vehicle can be waxed with any non-abrasive automotive paste wax. Avoid the use of harsh cleaners since they can scratch the body finish.



**Certain products, including insect repellent and other chemicals, will damage plastic surfaces. Use caution when using these products near plastic surfaces.**

### Perform Repairs

Make necessary repairs to your vehicle before storing to prevent further damage the next time you operate it.

### Check the Tires

Inspect the tire treads and overall condition. Set the tires to the specified air pressure.

### Oil and Filter

Warm the engine, then stop the engine and change the oil and filter.

### Air Filter Element/Air Filter

Inspect and clean or replace air filter element. Clean the air filter and the sediment tube.

## **CLEANING & STORAGE**

### **Check Fluid Levels**

Inspect the following fluid levels and change if necessary:

- Front gear case
- Brake fluid (change every two years or as required if fluid looks dark or contaminated)
- Coolant (change every two years or as required if coolant looks contaminated)
- Fuel level (add fuel stabilizer according to the product label directions)

### **Stabilize the Fuel**

Fill the fuel tank with fresh fuel that has been treated with fuel stabilizer according to the product label directions. Do not allow untreated fuel to remain in the tank longer than 30 days, as the fuel begins to degrade and can cause damage to the fuel system components.

### **Battery Storage**

- Remove the battery from the vehicle and ensure that it is fully charged before placing it in storage. Protect the battery from freezing temperatures, which can damage the battery.

### **Lubricate**

Inspect all cables and lubricate with cable lubricant according to the product label directions. Grease the vehicle lubricating points with all-season grease.

## CLEANING & STORAGE

### 'Fog' the Engine

- Remove the rear access cover to access the spark plug(s).
- Remove the spark plug(s), rotate the piston to the bottom of its stroke, and pour approximately 0.6 oz. (15ml ~ 20ml) of engine oil into the opening.

### NOTE:

Do this carefully! If you miss the spark plug hole, oil will drain from the spark plug cavity, and appear to be an oil leak. To access the spark plug hole, use a section of clean hose and a small plastic squeeze bottle filled with the pre-measured amount of oil.

- Reinstall the spark plug(s). Torque the spark plug to specification.
- Turn the engine cover several times slowly. Oil will be forced in and around the piston, piston rings and the cylinder will be coated with a protective film of fresh oil.
- Reinstall the spark plug(s), cap(s), and side panel.

### NOTE:

Starting the engine during the storage period will disturb the protective film created by fogging. Corrosion could occur. Never start the engine during the storage period.

### Storage Area and Covering

Support the vehicle with stands under the frame with the tires 30 ~ 40mm (1.2 ~ 1.6 in.) off the ground. Be sure the storage area is well ventilated, and cover the machine with an approved cover.

### NOTE:

Do not use covers made of plastic or coated materials. They do not allow enough ventilation to prevent condensation, and may promote corrosion and oxidation.

## CLEANING & STORAGE

### NOTE

It is recommended to warm up the engine every 3 months and idle for 5 to 10 minutes so that the engine can be fully lubricated. Vehicles that have been disabled for a long time should avoid pulling or high speeds immediately after starting, which will cause excessive engine wear and affect the engine life.

## Transporting or Towing the Vehicle

### Transporting

- Place the transmission into the park position, engage the electronic parking brake, and block the front and rear wheels to prevent the vehicle from moving.
- Turn off the engine and remove the NFC key to prevent loss during transporting.
- Ensure the fuel cap is installed correctly and secure.
- Ensure panels, doors, and seats are installed correctly and secure.
- Secure the vehicle front and rear with straps to prevent it from sliding or moving during transport.

### Towing

- Place the transmission into neutral.
- Turn off the engine and remove the NFC key to prevent loss during transporting.
- Ensure the fuel cap is installed correctly and secure.
- Ensure panels, doors, and seats are installed correctly and secure.
- Tow the vehicle at low speed using a strap designed for such purpose. Attach only to the frame. Do not use chain or cable.

## VEHICLE ISSUE DIAGNOSIS

### Vehicle Issue Diagnosis

This section is intended to guide an average owner to simple items that could cause operating problems. Diagnosis of vehicle issues may require the experience of a dealership technician. Please contact your dealer if a solution is not apparent.

#### Engine Does Not Turn Over

Possible Cause	Solution
Blown fuse	Reset or replace the fuse
Low battery voltage	Recharge battery to 12.8 Vdc – Confirm battery state of health
Loose battery connections	Check all connections and tighten if necessary
Loose starter system electrical connections	Check all connections and tighten if necessary
Engine stop switch	Check function
Start circuit not complete – transmission in gear	Press foot brake or shift transmission to neutral or parking position

#### Engine Pings or Knocks

Possible Cause	Solution
Poor quality or low octane fuel	Replace with minimum 89 octane unleaded fuel
Incorrect ignition timing	See your dealer
Incorrect spark plug gap or heat range	Set spark plug gap to specs or replace plugs

## VEHICLE ISSUE DIAGNOSIS

### Engine Stops or Loses Power

Possible Cause	Solution
Overheated engine	Clean radiator screen and external core, clean engine exterior. See your dealer
Out of fuel	Inspect the level, refuel with minimum 89 octane unleaded fuel
Kinked or plugged fuel tank vent line	Inspect and replace. See your dealer
Water present in fuel	Replace with new fuel
Fouled or defective spark plugs	Inspect and clean or replace spark plug
Worn or defective ignition coil or wires	See your dealer
Incorrect spark plug gap or heat range	Set gap to specs or replace plug

## VEHICLE ISSUE DIAGNOSIS

Loose ignition connections	Check all connections and tighten
Low battery voltage	Recharge battery to 12.8 Vdc. Check charging system – Confirm battery health
Clogged air filter	Inspect and replace as necessary
Reverse speed limiter malfunction	See your dealer
Electronic throttle control malfunction	See your dealer
Other mechanical failure	See your dealer

## VEHICLE ISSUE DIAGNOSIS

### Engine turns over, Fails to start

Possible Cause	Solution
Engine fails to start	Refuel
Clogged fuel filter	Inspect and replace as necessary
Water present in fuel	Replace with 89 minimum octane unleaded fuel
Fuel pump failure	Inspect pump and fuse; Replace as necessary
Old or non-recommended fuel	Replace with 89 minimum octane unleaded fuel
Fouled or defective spark plugs	Inspect spark plugs, replace if necessary
No spark to spark plug	Inspect spark plugs, see your dealer if necessary
Crankcase filled with water or fuel	Immediately see your dealer
Clogged air filter	Inspect and replace as necessary
Clogged fuel injector	See your dealer
Low battery voltage	Recharge battery to 12.8 Vdc – Confirm battery health
Mechanical failure	See your dealer

## VEHICLE ISSUE DIAGNOSIS

### Engine backfires

Possible Cause	Solution
Weak spark from spark plugs	Inspect and replace spark plugs as necessary
Incorrect spark plug gap or heat range	Set gap to specs or replace plugs
Old or non-recommended fuel	Replace with minimum 89 octane unleaded fuel
Incorrectly installed spark plug wires	See your dealer
Incorrect ignition timing	See your dealer
Mechanical failure	See your dealer
Speed limiter malfunction	See your dealer

### Engine turns over, fails to start

Possible Cause	Solution
Fouled or defective spark plugs	Inspect spark plugs, replace if necessary
Worn or defective ignition coil or wires	See your dealer
Incorrect spark plug gap or heat range	Set gap to specs or replace plugs
Loose electrical connections	Check all connections and tighten
Water present in fuel	Replace with new fuel
Low battery voltage	Recharge battery to 12.8 Vdc. Inspect charging system
Kinked or plugged fuel tank outlet pipe	Inspect and replace as necessary
Incorrect used fuel	Replace with minimum 89 octane unleaded fuel
Clogged air filter element	Inspect and replace as necessary
Reverse speed limiter malfunction	See your dealer
Electronic throttle control malfunction	See your dealer

## VEHICLE ISSUE DIAGNOSIS

Possible Cause	Solution
Other mechanical failure	See your dealer
Fuel mixture may be lean or rich	See your dealer
Fouled fuel or low fuel	Replace or replenish the fuel, clean the fuel system
Low-octane fuel	Replace with minimum 89 octane unleaded fuel
Clogged fuel filter	Replace with the new filter
High-octane fuel	Replace with minimum 89 octane unleaded fuel

## VEHICLE ISSUE DIAGNOSIS

### EFI Malfunction Indicator Light

The Electronic Fuel Injection system on your vehicle contains a self-diagnostic feature that will illuminate the malfunction indicator light (MIL) if it detects a problem. In normal operation, the EFI indicator will be off.

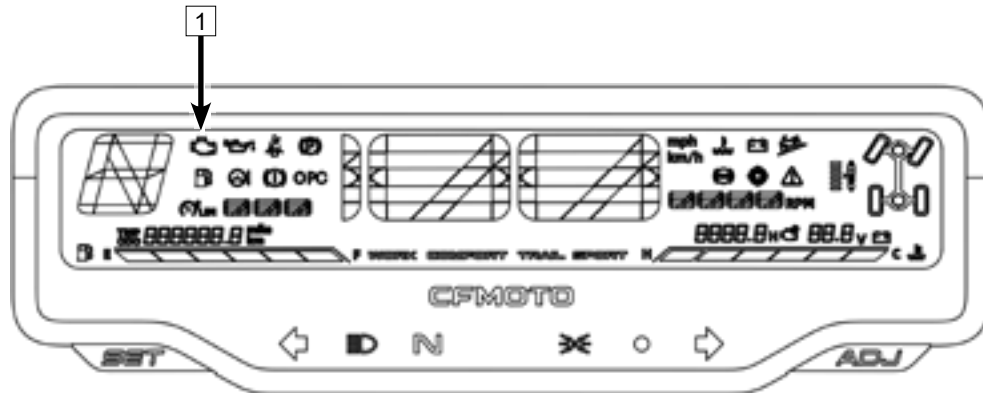

1 | EFI indicator

## VEHICLE ISSUE DIAGNOSIS

### EPS Malfunction Indicator Light

The Electronic Power Steering system on your vehicle contains a self-diagnostic feature that will illuminate the malfunction indicator light (MIL) if it detects a problem. When this indicator flashes, please contact your dealer. During normal operation, the EPS indicator will be on after the ignition switch is turned to ON, but EPS will not work. When the engine is started, the EPS indicator will be off and the EPS starts to function.

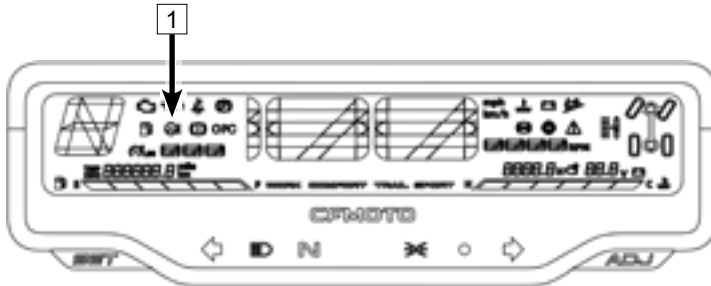

1 EPS Indicator

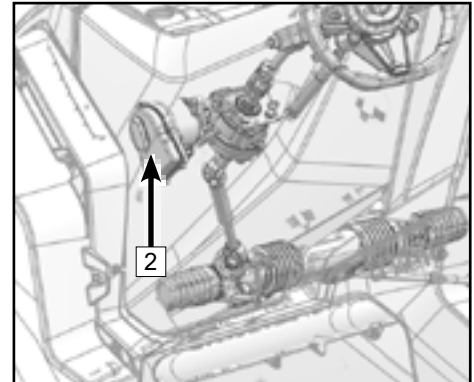

2 EPS

## VEHICLE ISSUE DIAGNOSIS

### Electronic Power Steering (EPS) Fault Diagnosis and Solution

Steering without assistance	<ol style="list-style-type: none"> <li>1. Wire connectors have bad contact or are disconnected</li> <li>2. The fuse blew out</li> <li>3. Relay damage</li> <li>4. The controller, motor, or sensor is damaged</li> </ol>	<ol style="list-style-type: none"> <li>1. Check whether wire connectors and pins are fully inserted</li> <li>2. Replace the fuse (40A)</li> <li>3. Contact your dealer</li> <li>4. Contact your dealer</li> </ol>
Power assist doesn't weigh the same for left and right	<ol style="list-style-type: none"> <li>1. The median output voltage has deviation</li> <li>2. Controller, motor or sensor is damaged</li> </ol>	<ol style="list-style-type: none"> <li>1. Contact your dealer</li> <li>2. Contact your dealer</li> </ol>
When system is 'ON', the steering swings to both sides	<ol style="list-style-type: none"> <li>1. Motor is mounted backwards</li> <li>2. Controller or sensor is damaged</li> </ol>	<ol style="list-style-type: none"> <li>1. Contact your dealer</li> <li>2. Contact your dealer</li> </ol>
Steering becomes heavy	<ol style="list-style-type: none"> <li>1. Battery has power loss</li> <li>2. Air pressure of the tires (front) is insufficient</li> <li>3. Motor damage (power reduction)</li> </ol>	<ol style="list-style-type: none"> <li>1. Charge the battery</li> <li>2. Inflate the tires</li> <li>3. Contact your dealer</li> </ol>
System has noise	<ol style="list-style-type: none"> <li>1. Motor damage</li> <li>2. Gap of lower steering shaft assembly or mechanical steering assembly is too large</li> <li>3. Installation of lower steering shaft assembly or mechanical steering assembly is loose</li> </ol>	<ol style="list-style-type: none"> <li>1. Contact your dealer</li> <li>2. Contact your dealer</li> <li>3. Contact your dealer</li> </ol>

# CFMOTO LIMITED WARRANTY FOR USA

## CFMOTO Limited Warranty

Dear Customer,

Thank you for purchasing a CFMOTO product, if any component on your vehicle is found to be defective in materials or workmanship within the terms and conditions of this Limited Warranty, the defective component will be repaired or replaced (at the option of CFMOTO) without charge for parts and/or labor at any authorized dealer located within the United States. The CFMOTO Limited Warranty is subject to the following terms and conditions:

### WARRANTY TERMS & CONDITIONS

- 1. WARRANTY DURATION:** The duration of the warranty period is one (1) year from the date of the new vehicle purchase from an authorized CFMOTO POWERSPORTS, Inc., Dealer. This warranty coverage is invoked from the purchase and use of CFMOTO vehicles only within the continental United States. During the warranty period, CFMOTO POWERSPORTS, Inc. will cover parts and labor costs incurred by an authorized CFMOTO POWERSPORTS, Inc. Dealer arising from a defect in material and/or workmanship of a CFMOTO vehicle. Any vehicles used for commercial purposes will have their warranty period reduced to six (6) months. If CFMOTO POWERSPORTS, Inc. covers a full engine replacement or a complete vehicle replacement under this warranty, the warranty period does not get extended and remains the same as the original purchase date of the vehicle at issue.
- 2. WARRANTY LIMITATIONS:** CFMOTO POWERSPORTS, Inc. provides warranty coverage for one (1) year on all parts and labor for all of its new CFMOTO ATVs. However, the following coverage, exceptions, and limitations apply to all CFMOTO vehicles:

## **CFMOTO LIMITED WARRANTY FOR USA**

**A.** A 30-DAY WARRANTY coverage period applies to all new CFMOTO vehicles in relation to the vehicle's:

- Battery
- Spark Plugs
- Air Filters
- Oil and Fuel Filters

**B.** A 90-DAY WARRANTY coverage period applies to all new CFMOTO vehicles in relation to the vehicle's:

- Drive Belt
- Gear Shift, CVT, and Wet Clutch
- Throttle and Brake Cables
- Front/Rear Rims
- Front/Rear Tires
- Front/Rear Brake Pads or Shoes
- Front/Rear Brake Discs or Drums
- Wheel or Steering Stem Bearings and Seals
- Rubber Parts/Engine Mounts/Grips/Boots
- Brake or Clutch Levers
- Floor Boards or Pegs
- ATV Winch (if equipped)
- Light Bulbs/Fuses
- Body Plastics and Cosmetic Defects

## CFMOTO LIMITED WARRANTY FOR USA

- 3. EXCLUSIONS FROM WARRANTY COVERAGE:** Any Damage resulting from the following acts or circumstances is not covered by the CFMOTO POWERSPORTS, Inc., Limited Warranty:
- Fire
  - Collision
  - Theft
  - Unavoidable natural disasters
  - Improper storage or transportation
  - Failure or negligence in the performance of periodic vehicle maintenance
  - Improper or negligent use or operation
  - Unauthorized repair or adjustment
  - Unauthorized modifications or performance upgrades
  - Use of vehicle as a rental vehicle
  - Use of vehicle in competitive or racing events
- 4. VEHICLE CARE AND MAINTENANCE:** The vehicle's owner must properly use, maintain, and care for the vehicle as outlined in the CFMOTO POWERSPORTS, Inc., Owner's Manual. Any warranty repairs must be performed exclusively by CFMOTO POWERSPORTS, Inc., authorized Dealers. Any warranty work performed by anyone other than an authorized CFMOTO Dealer will not be covered under the CFMOTO POWERSPORTS, Inc., Limited Warranty policy.

## CFMOTO LIMITED WARRANTY FOR USA

- 5. TRANSFER OR CONTINUATION OF WARRANTY:** This warranty is transferable only under the following conditions:
- Transfer information must be provided to an authorized CFMOTO POWERSPORTS, Inc. dealer, who will then forward the information to CFMOTO POWERSPORTS, Inc.;
  - The complete model and serial number as shown on the original warranty document must be provided.
  - The name and address of the existing and new owners must be provided.
  - The original delivery date of the vehicle must be provided.
  - The new owner must indicate in writing that he/she has received and read the vehicle's Owner's Manual and the CFMOTO POWERSPORTS, Inc. Warranty Policy.
- 6. WARRANTY REGISTRATION:** The Dealer must complete a PDI form and warranty register the vehicle online and provide the completed registration form to CFMOTO POWERSPORTS, Inc., within seven (7) days of completing the sale of the vehicle. Please note that NO warranty claims will be processed unless the product warranty online registration form is completed and the form is received by CFMOTO POWERSPORTS, Inc., from the Dealer.
- 7. DEALER RESPONSIBILITIES:** A CFMOTO authorized Dealer must perform warranty coverage repairs at no charge to the customer, even if they are not the dealer that sold the CFMOTO vehicle to the customer, and must use CFMOTO OEM parts for all warranty repairs. All vehicles sold by the dealer must be inspected and tested by the dealer to ensure proper performance and operation prior to delivery to the customer. No vehicles may be delivered to a customer without first passing a dealer inspection and an operational test.

## CFMOTO LIMITED WARRANTY FOR USA

8. **CUSTOMER ASSISTANCE:** Any questions or concerns regarding your CFMOTO vehicle or related products should be directed to an authorized CFMOTO dealer. However, if a dealer is unable to address customer concerns or a product issue, CFMOTO POWERSPORTS Customer Service can be contacted directly at (763) 398-2690 or by e-mail: [info@cfmoutousa.com](mailto:info@cfmoutousa.com). Please note that Customer Service is not authorized to approve or deny warranty, and cannot provide technical repair data, diagnosis, instruction, or other information beyond what is provided in the Owner's Manual.
9. **COMMERCIAL USE.** The duration of the warranty for commercial use shall be limited to a period of six (6) months instead of one year for recreational use. All other conditions and limitations shall apply.
10. **TIRES PROVIDED AS ORIGINAL EQUIPMENT:** Other than provided herein, vehicle tires supplied as original equipment are warranted separately by the individual tire manufacturer or its representatives.
11. **DISCLAIMER:** NO EXPRESS WARRANTY IS PROVIDED BY CFMOTO POWERSPORTS, INC. WITH RESPECT TO CFMOTO VEHICLES EXCEPT AS SPECIFICALLY SET FORTH HEREIN. ANY IMPLIED WARRANTY, WARRANTY OF MERCHANTABILITY, WARRANTY OF FITNESS FOR A PARTICULAR PURPOSE, AND ALL IMPLIED WARRANTIES ARISING FROM A COURSE OF DEALING, USAGE OF TRADE, BY STATUTE OR OTHERWISE, ARE HEREBY STRICTLY LIMITED TO THE TERMS OF THIS WRITTEN LIMITED WARRANTY.

## **CFMOTO LIMITED WARRANTY FOR USA**

**12. INTEGRATION:** This limited warranty supersedes any and all oral, express, or written warranties, statements, or undertakings that may previously have been made, and contains the entire agreement of the parties with respect to the warranty of CFMOTO vehicles. Any and all warranties not contained in this Agreement are specifically excluded. This warranty extends to each original (and subsequent) owner of any CFMOTO ATV, for the term of the original warranty period. This limited warranty shall be the sole and exclusive remedy available to the customer with respect to the covered CFMOTO vehicle. In the event of any alleged breach of any warranty or any legal action brought by the customer based on alleged negligence or other conduct by CFMOTO POWERSPORTS Inc., or its related parties, the customer's sole and exclusive remedy will be repair or replacement of defective components as stated above, unless otherwise provided by law. Some states do not allow limitations on how long an implied warranty lasts, so the above limitations may not apply if they are deemed inconsistent with the controlling state law.

# **CFMOTO LIMITED WARRANTY FOR USA CALIFORNIA EVAPORATIVE EMISSIONS CONTROL WARRANTY STATEMENT YOUR WARRANTY RIGHTS AND OBLIGATIONS**

## **INTRODUCTION:**

The California Air Resources Board (CARB) and CFMOTO Powersports, Inc. (CFMOTO) are pleased to explain the evaporative emissions control system warranty on your 2020 and later-model year off-highway recreation vehicles (OHRVs). In California, new off-highway recreational vehicles must be designed, built, and equipped to meet the State's stringent anti-smog standards. CFMOTO must warrant the evaporative emissions control system on your OHRV for the periods of time listed below, provided there has been no abuse, neglect, improper maintenance, or unapproved modification of your OHRV.

Your evaporative emissions control system may include parts such as: fuel injection systems, electronic control systems, fuel tanks, fuel lines, fuel caps, valves, carbon canisters, filters, vapor hoses, belts, clamps, connectors, and other evaporative emissions-related components. Where a warrantable condition exists, CFMOTO will repair your OHRV at no cost to you, including diagnosis, parts and labor.

## **MANUFACTURER'S WARRANTY COVERAGE:**

The warranty period for this OHRV is 30 months, or 2500 miles, or 250 hours, whichever comes first, except for "high-priced" warranty parts, which are covered for 60 months, or 5000 miles, or 500 hours, whichever comes first. If any evaporative emissions-related part on your OHRV is defective, the part will be repaired or replaced by CFMOTO.

## **OWNER'S WARRANTY RESPONSIBILITIES:**

As the OHRV owner, you are responsible for the performance of the required maintenance listed in your owner's manual. CFMOTO recommends that you retain all receipts covering maintenance on your OHRV, but CFMOTO cannot deny warranty solely for the lack of receipts or for your failure to ensure the performance of a scheduled maintenance.

## CFMOTO LIMITED WARRANTY FOR USA

As an owner, you are responsible for presenting your OHRV to a CFMOTO dealer as soon as a problem exists. The warranty repairs should be completed in a reasonable amount of time, not to exceed 30 days. As an OHRV owner, you should also be aware that CFMOTO may deny you warranty coverage if your OHRV or a part has failed due to abuse, neglect, improper maintenance or unapproved modifications.

### WARRANTY PARTS:

The repair or replacement of any warranted part otherwise eligible for warranty coverage may be excluded from such coverage if CFMOTO demonstrates that the OHRV has been abused, neglected, or improperly maintained, and that such abuse, neglect, or improper maintenance was the direct cause of the need for repair or replacement of the part. That notwithstanding, any adjustment of a component that has a factory installed, and properly operating, adjustment-limiting device is still eligible for warranty coverage. The following emission warranty parts list are covered:

- Fuel Tank<sup>§</sup>
- Fuel Cap
- Fuel Lines
- Fuel Lines Fittings
- Clamps
- Pressure Relief Valves\*
- Control Valves\*
- Control Solenoids\*
- Electronic Control\*
- Electronic Control Module\*<sup>§</sup>
- Vacuum Control Diaphragms\*
- Control Cables\*
- Control Linkages\*
- Purge Valves
- Vapor Hoses
- Liquid/Vapor Separator
- Carbon Canister
- Canister Mounting Brackets

\*Parts that relate to the installed vehicle Evaporative Control System; §=High-Priced warranty parts.

**THE REMOVAL OR MODIFICATION OF EVAPORATIVE EMISSION-RELATED PARTS ON THIS OHRV IS ILLEGAL. VIOLATORS MAY BE SUBJECT TO CIVIL AND/OR CRIMINAL PENALTIES AS PROVIDED UNDER CALIFORNIA AND FEDERAL LAW.**

If you have any questions regarding your warranty rights and responsibilities, you should contact CFMOTO at 763 398-2690; 555 Holly Lane N. Suite #30 Plymouth, MN 55447 or the California Air Resources Board at 9528 Telstar Avenue, El Monte, CA 91731.

## **CFMOTO LIMITED WARRANTY FOR USA**

### **U.S.A. EPA and CARB Emissions Control Limited Warranty**

This emissions limited warranty is in addition to the CFMOTO Powersports, Inc. standard limited warranty for your vehicle. CFMOTO Powersports, Inc. warrants that at the time it is first purchased, this emissions-certified vehicle is designed, built and equipped so it conforms to applicable U.S. Environmental Protection Agency (EPA) and the California Air Resource Board (CARB) emission regulations. CFMOTO Powersports, Inc. also warrants that the vehicle is free from defects in materials and workmanship that would cause it to fail to meet these regulations.

The warranty period for this emissions-certified vehicle starts on the date the vehicle is first purchased and continues for a period of 500 hours of engine operation, 5000 kilometers (3,100 miles) of vehicle travel, or 30 calendar months from the date of purchase, whichever comes first. This emissions limited warranty covers components whose failure increases the vehicle's regulated emissions, and it covers components of systems whose only purpose is to control emissions. Repairing or replacing other components not covered by this warranty is the responsibility of the vehicle owner. This emissions limited warranty does not cover components whose failure does not increase the vehicle's regulated emissions.

For exhaust emissions, emission-related components include any engine parts related to the following systems:

- Air-induction system (excludes filters)
- Ignition system (excludes spark plugs)
- Fuel system (excludes filters)
- Exhaust gas recirculation systems

The following parts are also considered emission-related components for exhaust emissions:

- After treatment devices
- Sensors
- Crankcase ventilation valves
- Electronic control units

## **CFMOTO LIMITED WARRANTY FOR USA**

The following parts are considered emission-related components for evaporative emissions:

- Fuel Tank
- Fuel Cap
- Fuel Line
- Fuel Line Fittings
- Clamps\*
- Pressure Relief Valves\*
- Control Valves\*
- Electronic Controls\*
- Vacuum Control Diaphragms\*
- Control Cables\*
- Control Linkages\*
- Purge Valves
- Vapor Hoses
- Liquid/Vapor Separator
- Carbon Canister
- Carburetor Purge Port Connector

\* As related to the evaporative emission control system.

The exclusive remedy for breach of this limited warranty shall be, at the exclusive option of CFMOTO Powersports, Inc., repair or replacement of any defective materials, components or products.

THE REMEDIES SET FORTH IN THIS LIMITED WARRANTY ARE THE ONLY REMEDIES AVAILABLE TO ANY PERSON FOR BREACH OF THIS WARRANTY. CFMOTO POWERSPORTS, INC. SHALL HAVE NO LIABILITY TO ANY PERSON FOR INCIDENTAL, CONSEQUENTIAL OR SPECIAL DAMAGES OF ANY DESCRIPTION, WHETHER ARISING OUT OF EXPRESS OR IMPLIED WARRANTY OR ANY OTHER CONTRACT, NEGLIGENCE OR OTHER TORT OR OTHERWISE. THIS EXCLUSION OF CONSEQUENTIAL, INCIDENTAL, AND SPECIAL DAMAGES IS INDEPENDENT FROM AND SHALL SURVIVE ANY FINDING THAT THE EXCLUSIVE REMEDY FAILED OF ITS ESSENTIAL PURPOSE.

## **CFMOTO LIMITED WARRANTY FOR USA**

ALL IMPLIED WARRANTIES (INCLUDING BUT NOT LIMITED TO ANY IMPLIED WARRANTIES OF MERCHANTABILITY AND FITNESS FOR A PARTICULAR PURPOSE) ARE LIMITED IN DURATION TO THE WARRANTY PERIOD DESCRIBED HEREIN. CFMOTO POWERSPORTS, INC. DISCLAIMS ALL EXPRESS WARRANTIES NOT STATED IN THIS WARRANTY.

Some states do not allow limitations on how long an implied warranty lasts, so the above limitation may not apply if it is inconsistent with the controlling state law. This limited warranty excludes failures not caused by a defect in material or workmanship. This limited warranty does not cover damage due to accidents, abuse or improper handling, maintenance or use. This limited warranty also does not cover any engine that has been structurally altered, or when the vehicle has been used in racing competition. This limited warranty also does not cover physical damage, corrosion, or defects caused by fire, explosions or other similar causes beyond the control of CFMOTO Powersports, Inc. Owners are responsible for performing the scheduled maintenance identified in the owner's manual. CFMOTO Powersports, Inc. may deny warranty claims for failures that have been caused by the owner's or operator's improper maintenance or use, by accidents for which CFMOTO Powersports, Inc. has no responsibility, or by acts of God. Any qualified repair shop or person may maintain, replace, or repair the emission control devices or systems on your vehicle. CFMOTO Powersports, Inc. recommends that you contact an authorized CFMOTO Powersports, Inc. dealer to perform any service that may be necessary for your vehicle. CFMOTO Powersports, Inc. also recommends that you use only genuine CFMOTO Powersports, Inc. parts. It is a potential violation of the Clean Air Act if a part supplied by an aftermarket parts manufacturer reduces the effectiveness of the vehicle's emission controls. Tampering with emission controls is prohibited by federal law. If you have any questions regarding your warranty rights and responsibilities, please contact CFMOTO Powersports, Inc. at 888-823-6686.

## **CFMOTO LIMITED WARRANTY FOR USA**

### **Noise Control System and Tampering**

Warranty time period: **1,865 miles (3000 km)**

Federal law prohibits the following acts or causing thereof:

1. The removal or rendering inoperative by any person other than for purposes of maintenance, repair, or replacement, of any device or element of design incorporated into any new vehicle for the purpose of noise control prior to its sale or delivery to the ultimate purchaser or while it is in use or;
2. The use of the vehicle after such device or element of design has been removed or rendered inoperative by any person.

**AMONG THOSE ACTS PRESUMED TO CONSTITUTE TAMPERING ARE THE ACTS LISTED BELOW:**

These acts include tampering with the following systems; i.e., modification, removal, etc.

Exhaust system

- Muffler
- Exhaust
- Silencer

Intake system

- Air cleaner case
- Air cleaner element
- Intake duct

## CFMOTO LIMITED WARRANTY FOR USA

### Change of Ownership

If you sell your vehicle, any valid remainder of the warranty can be transferred to the new owner. Please record the details of the exchange below and inform an authorized CFMOTO dealer:

Change of Ownership	Original Purchaser	2nd Owner	3rd Owner	4th Owner
Owner Name				
Address				
City				
State / Zip Code				
Telephone				
E-mail				
Date of Purchase				
Odometer Reading				
New Owner Signature				

#### NOTE:

If a completed Change of Ownership form does not include the required details or is inaccurate, CFMOTO reserves the right to investigate the actual ownership of the product, the service history, and possibly refuse the application for warranty transfer if the requirements have not been fulfilled.

## CFMOTO RIDE App / Telematics Box

CFMOTO RIDE is an intelligent, networked, mobile service platform that provides human-vehicle interconnection as its core. CFMOTO RIDE is committed to providing full-featured services for motorsport enthusiasts online.

The telematics module, or T-BOX, is an intelligent vehicle terminal that builds a communication bridge between owners and vehicles through the CFMOTO RIDE App. When T-BOX equipped, the owner can enjoy the smart features of CFMOTO RIDE.

The telematics module is optional in select markets. Check with your dealer to determine if your vehicle is equipped with telematics (T-BOX), or download the CFMOTO RIDE App, send your question via the [feedback] option, and CFMOTO will check for you.



CFMOTO RIDE App

Scan the QR code to download the CFMOTO RIDE APP from the Apple App Store for iPhone or Google Play for Android.



CFMOTO RIDE Facebook

Scan the QR code to follow CFMOTO RIDE on Facebook and be first to receive notices on App updates and news.



CFMOTO RIDE Website

Scan the QR code to explore the CFMOTO RIDE intelligent platform on the CFMOTO global website.

CFMOTO RIDE provides various smart features such as the vehicle owner's manual, riding details, navigation, Over-The-Air (OTA) updates, geo-fence, static reminders, etc. Available features will vary according to vehicle / model configuration and global market requirements.

Please download CFMOTO RIDE and enjoy the intelligent riding experience!

## **CFMOTO RIDESYNC APP / TELEMATICS MODULE (Select Markets)**

CFMOTO RideSync is an intelligent, networked, mobile service platform that provides human-vehicle interconnection as its core. CFMOTO RideSync is committed to providing full-featured services for motorsport enthusiasts online. The telematics module, or T-BOX, is an intelligent vehicle terminal that builds a communication bridge between owners and vehicles through the CFMOTO RideSync App. When a T-BOX is equipped, the owner can enjoy the smart features of the app. The telematics module is optional in select markets. Check with your dealer to determine if your vehicle is equipped with telematics (T-BOX). Or download the CFMOTO RideSync App, send your question via the [feedback] option, and CFMOTO will check for you.



CFMOTO RideSync

Scan the QR code to download the CFMOTO RIDE /  
RIDESYNC APP from the Apple App Store for iPhone or  
Google Play for Android.

CFMOTO RideSync provides various smart features such as the vehicle owner's manual, riding details, navigation, Over-The-Air (OTA) updates, geo-fence, static reminders, etc. Available features will vary according to vehicle / model configuration and global market requirements. Please download CFMOTO RideSync and enjoy the intelligent riding experience!

## FOX ELECTRONIC SUSPENSION APP (Select Markets)

CFMOTO is committed to providing full-featured services for motorsports enthusiasts with human-vehicle interconnection as its core, and has partnered with FOX to provide an exciting and easy electronic suspension adjustment system to help keep drivers and passengers comfortable on the trail.

### STEP 1 - Download the FOX FACTORY APP on your mobile device:



### STEP 2 - Create an account:

To get the full Fox Factory App experience, you must allow / enable the following services on your device:

#### Location Services / Notification Services / Bluetooth Services (For connecting)

These services enable full communication between the vehicle and your device, such as advanced diagnostics, independent front/rear suspension tuning, saving custom tunes, and display of key performance metrics.

### STEP 3 - Pair your vehicle:

Once you've completed steps 1 and 2, you will need to enter the Pairing Mode on your vehicle. Starting in the 'OFF' position and without pressing the brake pedal, press the start button once to power your Z10 'ON' without starting the engine. Next, (without touching brake pedal) cycle the start button 3 times from 'OFF' to 'ON' and leave 'ON' the 3rd cycle. The vehicle will confirm it is ready to pair, and an MMI message will display indicating that Pairing Mode is active.

### STEP 4 - Finalize the connection:

Click 'SCAN' in the FOX Factory App to begin scanning for your vehicle. If vehicle is in pairing mode properly, the app will find and display your vehicle on the Select Vehicle screen. *NOTE: If your vehicle does not appear when scanning and you did not receive the pairing mode message, turn the vehicle OFF for more than 35 seconds and repeat Step 3.*



5DYV-380101-1000-13 US248

ZHEJIANG CFMOTO POWER CO., LTD.

MANUFACTURED BY:

Add:NO.116,Wuzhou Road, Yuhang Economic Development  
Zone,Hangzhou 311100,Zhejiang Province,China  
Tel:86-571-86258863 Fax:+86-571-89265788  
E-mail:service@cfmoto.com.cn <http://global.cfmoto.com>

DISTRIBUTED BY:

CFMOTO POWERSPORTS INC.

5005 Nathan Lane N.,Plymouth MN, 55442, USA  
Toll free: (888) 8-CFMOTO (823-6686)  
Tel: (1) 763-398-2690 Fax: (1) 763-398-2695  
[www.cfmotousa.com](http://www.cfmotousa.com)

DISTRIBUTED BY

CANADA MOTOR IMPORT INC.

24 rue Industrielle, Saint-Benoît Labre,  
Québec, Canada, G0M 1P0  
Tel:418-227-2077  
[www.cfmoto.ca](http://www.cfmoto.ca)